



ACF: 170.

Radial Bladed Blowers with optional and Acoustic Enclosures



Installation, operation and maintenance instruction manual

Air Control Industries Ltd
Silver Street - Chard - Somerset - TA20 2AE - UK
Tel: +44(0)845 5000 501 - Fax: +44(0)845 5000502
Email: sales@aircontrolindustries.com
Web: www.aircontrolindustries.com

WARNING

All service procedures and electrical work should only be performed by trained personnel.

IMPORTANT

Please read the following installation, operation and maintenance instructions carefully. Always ensure that the power is isolated and locked off before commencing any maintenance on a radial bladed blower unit. The following manual is also available from the download section of our website: www.aircontrolindustries.com

DESCRIPTION AND MODEL IDENTIFICATION

ACI's radial bladed blower is an industrial type radial bladed centrifugal blower.

Air Control Industries Ltd's label each blower unit on the back of the motor cowl label. The serial number can be located on this label.

The RB range is constructed from a steel-sheet in both a pressed or fully fabricated format. The units are made up of the following components:

- Motor - normally supplied in a standard metric frame, squirrel cage induction type.
- Impeller - radial bladed constructed from welded and riveted sheet steel. The impeller is secured to the motor shaft by a gib-head key.
- Casing/Pedestal - constructed from press formed or welded sheet stiffened with steel angle. The motor mounting pedestal is integral with the casing.
- Inlet - fans operate at high speeds and the inlet can have a high suction power. When operating please ensure that there are no person(s) stood in front of the inlet. Never run the fan without a guard or filter.
- Outlet - fan discharge velocity can be very high. Debris can be sucked into the fan and discharged at high speed. When operating, person(s) should not be stood at the outlet aperture.

EQUIPMENT ARRIVAL / INSPECTION

Inspect the blower unit at the time of receipt to ensure that all components and accessories, as documented on the delivery note, were received and in good condition. Inspect the blower and motor assembly to ensure that the horsepower and voltage are correct.

If you have any shortages, discrepancies or damage, please contact your ACI Distributor or alternatively ACI at +44(0)845 5000 501.

OPERATING CONDITIONS

- Do not operate the fan unit in an explosive atmosphere except for certified fans.
- Each unit has a wiring diagram fitted as close to the connection area as possible. For example if the component machine is fitted with a terminal box, the diagram will be inside the box. If flying leads are fitted the diagram will be on the lead or on the motor itself. Protective circuitry is the customer's responsibility.
- All our motors are continuously rated; therefore frequent stop starts should be avoided. Start and stop control is dependant on customer installation. If the unit has been fitted with a speed controller please refer to the appropriate instructions that will be included.
- If the fan is supplied with an inverter please read the appropriate instructions that will be included.
- The fan should not be operated until it is connected to the system it will be operating in. Some motors will draw over the maximum current rating when in "free air".
- All fan units are tested to the correct supply voltage prior to them being despatched.

TRANSPORT, STORAGE

- ACI fans are packaged at the factory to comply with requirements for the agreed mode of transport.
- Transport of the fan(s) either in the original packaging or using the transport fixtures provided. Use suitable lifting equipment.
- Do not lift the fan by the connecting cable or fan impeller.
- When transporting manually, please refer to the EC guidelines for recommended maximum weight.
- Avoid excessive vibration and shockloads.
- Watch out for any damage to the packaging or the fan.

- Store the fan in the original packaging in a dry area protected from the weather or protect it from dirt or weather until final installation.
- Avoid exposure to extreme heat and cold.
- Avoid excessive storage periods (we recommend one year max.) and inspect the motor bearings for proper operation prior to installation.

INSTALLATION

- Installation, electrical connection and commissioning are only to be performed by trained service personnel. Adhere to all machinery-related requirements and specifications supplied by the system manufacturer or machine builder. Failure to comply will invalidate the guarantee on our fans and accessories.

The following applies for all ACI fans:

- Do not install without adequate support
- Flange and mounting brackets must be fixed flat on a level surface.
- Do not apply force
- Secure all connection points with a suitable fastener.
- Secure bolted connections with a locking compound.
- Do not use metal compression-gland fittings with plastic terminal boxes.
- For operation under extreme conditions use pre-installed sealing elements.
- For control equipment, refer to t and follow the safety instructions supplied with the equipment.

OPERATION

Before starting the fan check that there are no foreign bodies inside it otherwise these could be ejected at high speed with considerable force.

1. Mounting

The inlet must be placed in a clean and dry area well away from possible sources of liquid contamination. If the fan is to be placed in an enclosure adequate ventilation should be provided for the motor. If the fan is to be mounted on / within machinery that transmits vibration, anti vibration mounts should be used.

2. Location

Ambient temperature conditions should range from -10 to +45 degrees centigrade and adequate ventilation provided for the motor. In factory locations subject to high-pressure water or caustic wash-down cycles, protect or relocate the blower to prevent damage.

3. Blower Connections

Both the inlet and discharge can be fitted with wire mesh guards, filters and/or spigots to aid connection to different ducting depending on your requirements.

Flexible hose can introduce a high-pressure drop and lengths should therefore be kept to a minimum.

4. Drive Motor

Units are typically driven by induction type electric motors. If alternative motors are supplied, reference to the motor rating plate is required for all electrical details. The fan is designed to be continuously run at its designated speed, any inverter drive program giving speed control and/or speed changes must be approved by ACI.

5. Shaft Rotation

Check that the rotation of the blower is in accordance with the arrow on the unit. Note: If the fan rotates backwards, it will still operate but with a reduced performance of around 60% max.

6. Filters

The standard inlet filters have a filtration rate of 5-7 microns. ACI recommend that the filters are inspected at least once a month and washed at six month intervals with warm soapy water and thoroughly dried before being refitted. Filters should be replaced annually (Time scales will depend on the environment.). Different grade filters can be purchased through ACI.

Pre-start checks

- Check that there is no debris in the fan.
- Check that the guards have not been damaged and are still effective.
- Ensure the fan is free to rotate.
- Check that the supply cable is not damaged and the earth terminal is secure.
- Ensure all access covers are in place and secure.
- Ensure the inlet guard or inlet filter is clean and un-obstructed.

Start Procedure

- Start the fan.
- Check for a smooth run-up to full speed.
- Check for fan vibration.
- Check the fan is making no undue noise.

Routines While Operating

- Check that there is no fan case leakage.
- Check that there is no discharge ductwork leaks.
- Check for fan vibration.
- Check the fan is making no undue noise.

Shut down Procedure

- Stop the fan.
- Check for smooth run-down.

MAINTENANCE INSTRUCTIONS

These units are designed to be a minimum maintenance device. However, the execution of a few basic maintenance functions will extend the life of the mechanical components and ensure continued efficiency and longevity.

In the event of maintenance needing to be carried out, the fan unit is easily dismantled using standard engineer's tools. No special tools are required. A suitable means of lifting the motor and the impeller may be required.

WASH DOWN

Care must be taken to avoid soaking the blower/filter or allowing wash down liquid to enter any slots or nozzles that may allow fluid to pass back down through the supply hoses to the blower itself.

FILTERS

If required, filters will be directly fitted to the blower inlet, and in the case of the an acoustic enclosure, additional filtration will be provided by the built in cover filters.

The standard inlet filters have a filtration rate of 5-7 microns. We recommend that the filters are inspected at least every month and replaced every 6 months. Actual timescales depend on the working environment.

If a breakdown occurs after a 12 month period, only qualified engineers should attempt to resolve any work required:

REMOVAL OF IMPELLER

- Isolate the electric supply, disconnect the cable from the terminal box
- Mark the inlet front cover and fan case for re-alignment purposes.
- Undo and remove the fasteners securing the inlet from the fan case and lift off.
- Mark the exact position of the impeller on the shaft to enable exact repositioning when re-assembling.
- Push the impeller back towards the motor to release the gib-head key using the thread in the end of the motor shaft and a spacer arrangement. See Fig. 1
- Remove the gib-head key using a pinch bar or wedge. See Figs 2 & 3.
- Clean any protruding shaft in front of the impeller and soak in penetrating oil.
- Pull of the impeller using a hub puller.
- Take care not to damage the motor shaft.

Fig. 1

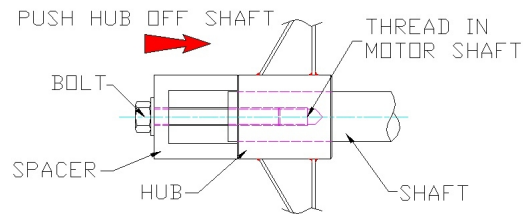

Fig 2.

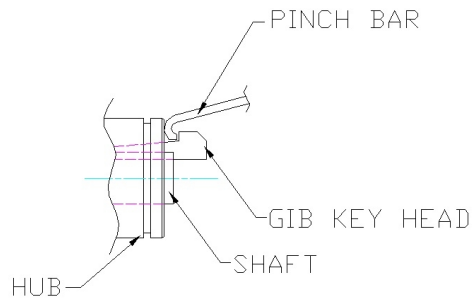
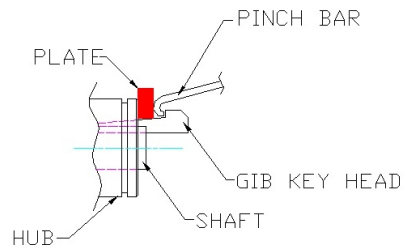

Fig 3.



REMOVAL & RE-ASSEMBLY OF MOTOR

- Remove the impeller, as explained in the previous section.
- Mark the motor and pedestal to enable re-fitting of the motor in exactly the same position.
- Undo and remove the fasteners securing the motor to the pedestal.
- Lift the motor off using the lifting equipment.
- Visually inspect the impeller, casing and motor shaft, paying particular attention to the welds.
- Clean and grease as required.
- Re-assembly is a reversal of the removal procedure.
- Lift the motor onto the pedestal, align using the alignment marks and secure using new fasteners. Tighten to secure.

ASSEMBLY OF IMPELLER

- Lightly smear the motor shaft and hub with grease to prevent oxidation.
- Slide the impeller hub onto the motor shaft and loosely fit the gib-head key.
- Ensure the alignment marks line up.
- Rotate the impeller to ensure freedom of rotation and adequate clearances.

- Re-assemble the inlet front cover assembly to the fan case, positioning using the alignment marks. Fit nuts and washers and tighten to secure.
- Check that the impeller gaps are correct. This can be checked by spinning the impeller by hand and making sure that the impeller is not catching.
- Drive in the gib-head key to lock.
- The manual filing of the gib-head key may be required. Use Engineers Blue to ensure contact along the length of the key.
- Re-connect the supply cable.
- Blank off the inlet briefly until running at normal speed. Continue running for approximately 5 minutes to ensure that the impeller is not catching and bearings are not over heating. Stop the fan.
- Remove the blank from the fan inlet and re-connect ductwork.
- Carry out pre-start check.
- Carry out start up.

LUBRICATION - FAN DRIVE UNITS

The direct driven fans do not have separate bearings, but rely upon the motor bearings for support. Some larger wattage motors may be fitted with grease nipples, for these units the motor manufacturer's literature should be consulted for lubricant type and periodicity. In the absence of this information the following practice should be adopted.

Temperature (degrees centigrade)	Lubricant	Periodicity
-30 to +130	Shell Avania R3	1 or 2 shots every 6 months

If the working environment is dirty and the atmosphere is laden with dust, it may advisable to regularly clean the motor casing to ensure adequate cooling.

FAN SPARE PARTS

If you require any spare parts for this fan type, please call ACI's Technical Sales Department on +44 (0) 845 5000 501.

TROUBLESHOOTING

(This section is not intended as an exhaustive guide to fault diagnosis, but outlines the most common faults that may be encountered.)

Condition	Possible Cause	Action
Fan stopped	Motor fuse blown	Replace with correct size fuses and investigate the reason for fuses blowing.
	Motor tripped on overload	Reset the overload and check overload setting and investigate the reason for the trip.
	Blockage between blades and casing	Find and remove blockage, inspect for damage and replace damaged parts.
Fan pressure high	Blockage downstream of fan	Remove blockage, dismantle if necessary.
	Supply frequency increased.	Check against motor specification.
Fan pressure low	Fan rotating backwards	Briefly apply power to the blower and check the rotation of the motor by looking at the motor cooling fan. The direction should be as per the arrow.
	Fan not running	Ensure that the power is switched on and selected to automatic, and protection has not been operated.
	Blocked inlet filter/guard and silencer	Check intake for cleanliness, clean or change filter.
	Fan blades damaged	Repair damage and rebalance or fit new impeller.

	Ductwork leakage.	Repair ductwork.
Fan Vibrating	Fan blade damaged.	Repair damage and rebalance or fit new impeller.
	Debris drawn into fan and attached to a blade.	Remove debris, repair blade and rebalance, or fit a new impeller.
Noisy fan	Debris in fan.	Remove and inspect for damage, repair as necessary.
	Motor bearing wear.	Check and fit new bearings ensuring lubrication.
	Fan impeller loose.	Tighten or re-weld, test for vibration.
Fan drawing high current	Discharge area too large.	Check for ducting leaks. Check total discharge area is as per system design.
	Motor bearing wear.	Check and fit new bearings ensuring lubrication.
	Increase in motor speed.	Check that the supply frequency is correct.

ACOUSTIC ENCLOSURES

This unit has been designed for ease of handling and installation. Being modular in construction it can handle the following blower discharge angle. Please note for both the R270 and L270 access require access through the floor.

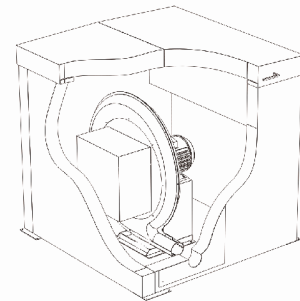

POSITIONING

It is essential that the blower is mounted within the enclosure in the orientation shown opposite with the motor facing the inlet filters to enable cool air entering the enclosure to pass over the motor before entering the blower inlet.

If both the inlet and discharge are ducted, an acoustic enclosure with an ambient air -duct can be used, this will still allow air to pass over the motor keeping it cool.

Consideration should be given to the positioning of the blower and panels for access purposes. Inlets should be clear of obstruction and sited at least 0.5M away from any wall.

Both the blower and enclosure are free-standing and should be located on a level floor capable of taking the combined weight.

ELECTRICAL CABLE ENTRY

The electrical cable can enter the enclosure through one of the two pre-drilled holes in the inlet panel or a cable entry can be drilled in any of the panels as required.

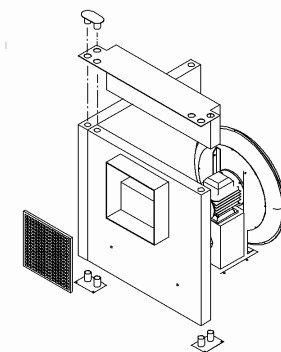

Stage 1

Place the radial bladed blower in the position required. Ensure that there is sufficient space for the enclosure and future access. Secure the blower to the floor using the fixings holes provided.

Stage 2

Place the inlet filter panel at the motor end as shown opposite, and insert the two joiners (floor). Ensure that the filter is in place and any protective packing is removed. When the blower inlet has ducting fitted this panel is replaced with one that has a cooling inlet for the motor.

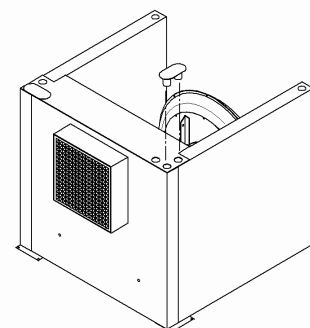

Stage 3

Take the discharge panel and overlap the filter panel on the side of the blower discharge engaging the lower joiner. Ensure that the blower discharge sits near the centre of the break-through panel.

Stage 4

Whilst supporting the two panels place the baffle plate in position and join the two panels using the joiner provided. Note this is not required or supplied when ducting is fitted to the blower inlet.

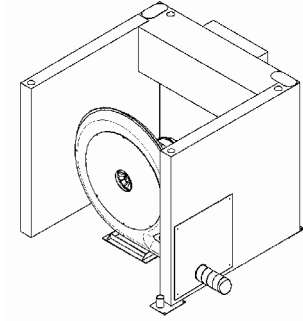

Stage 5

Take a plain panel and attach to the inside of the inlet panel engaging in the lower joiner. Then use a joiner through the baffle plate to secure.

Stage 6

With the enclosure in this condition connect the power supply to the blower through one of the cable entry points provided in the inlet panel using a suitable cable gland.

Stage 7

Connect the ducting to the blower. Cut a clearance hole in the break-through panel and fit this over the ducting to suit.

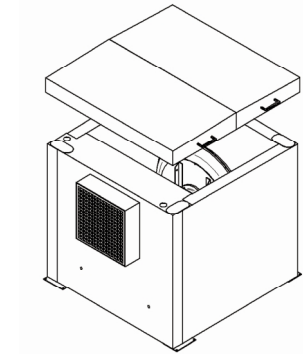

Stage 8

Fit the last panel and secure using the joiner and check that a minimum gap of 75mm is achieved between the blower inlet and inside surface of the panel.

Stage 9

Ensure the enclosure is square and then fit the two lid halves.

Stage 10

Secure the joiners to the floor through the holes provided.

WARRANTY & SERVICE EXCHANGE

Air Control Industries Limited (ACI) warrants all products manufactured by ACI to be free of defects in material and workmanship for twelve (12) months from the date of shipment. The warranty does not apply to drive belts, filter elements or connecting hose, unless authorised by an officer of ACI. Also, not covered under the warranty is normal wear and tear, neglect or misuse of the equipment, operation in an application not approved by ACI, and alterations not performed by ACI.

All items supplied by ACI that are manufactured by others shall be warranted under the respective manufacturer's policy. Motors and other items, for which a national service network is in place, should be sent directly to that manufacturer's representative for the most prompt service. ACI will provide any support required ensuring that warranty service by others is handled in a prompt and professional manner.

The ACI warranty is limited to the repair or replacement of items shipped by ACI. At no time will ACI be liable for any of the costs to the buyer for labour, transportation or down-time resulting from defective equipment furnished by ACI, or our suppliers.

To comply with the Warranty the complete fan unit must be returned to ACI. Disassembly of the fan will invalidate the warranty.

Manufacturer Service Address:

Our products are manufactured in compliance with applicable international standards and regulations. If you have any queries regarding the use of our products, or if you are planning a special application, please contact:

Air Control Industries Ltd
Silver Street - Chard - Somerset - TA20 2AE - UK

Tel: +44(0)845 5000 501
Fax: +44(0)0845 5000 502
Email: sales@aircontrolindustries.com
Web: www.aircontrolindustries.com