

### Performance details:

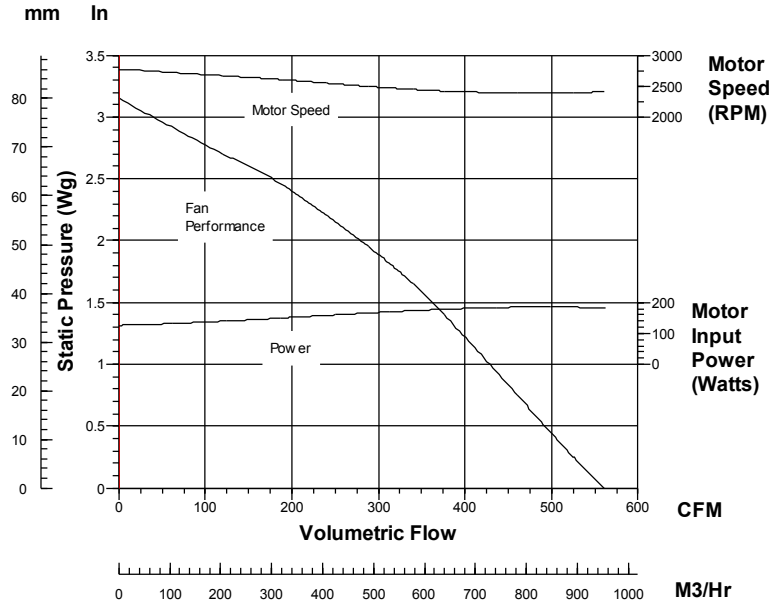

<b>Motor type:</b>	External rotor motor/shaded pole induction IP44
<b>Nominal supply:</b>	230V 1Ph 50/60Hz 115V 1Ph 50/60Hz
<b>Standard ancillaries:</b>	Inlet and discharge guards, spigots
<b>Materials:</b>	Fancase: cast aluminium LM6 Impeller: galvanised sheet steel
<b>Finishes:</b>	Stove enamel as std
<b>Mounting:</b>	Inlet and discharge drillings
<b>Noise levels:</b>	76 dB(A) Free Air, 1 metre
<b>Weight:</b>	6.8Kg

### Outline dimensions:

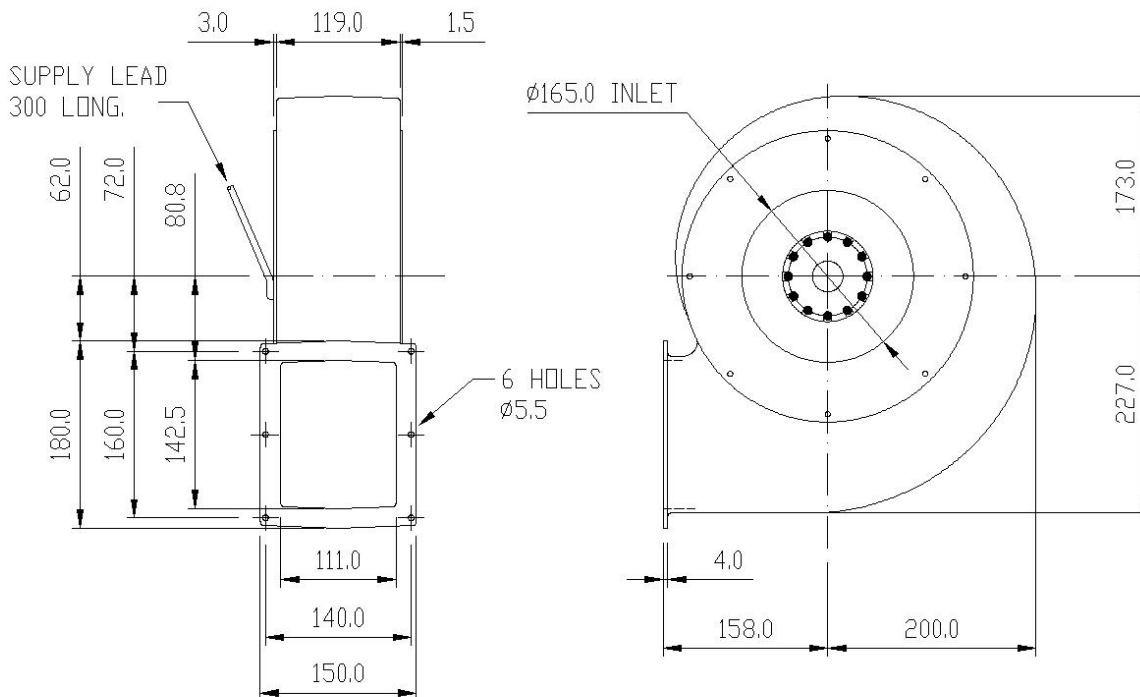

**Please note (1)** - all drawings measurements are in millimeters (mm)  
**Please note (2)** - above technical specifications are subject to change

**AIR CONTROL INDUSTRIES LTD.**  
 Silver Street, Chard, Somerset, UK, TA20 2AE  
 Tel: 0845 5000 501, Fax: 0845 5000 502

**AIR CONTROL INDUSTRIES INC.**  
 195 Augusta Rockland Road, Windsor, Maine, USA  
 Tel: 207-445-2518

[www.aircontrolindustries.com](http://www.aircontrolindustries.com) / [sales@aircontrolindustries.com](mailto:sales@aircontrolindustries.com)

Ref: Slimline VBL9/9 Iss 10/1



Certificate No. FM20497