



Air Control Industries

centrifugal VBL9/VBM9

Single Inlet Centrifugal Fan

ACI - Effective Air is our Business

Performance details:

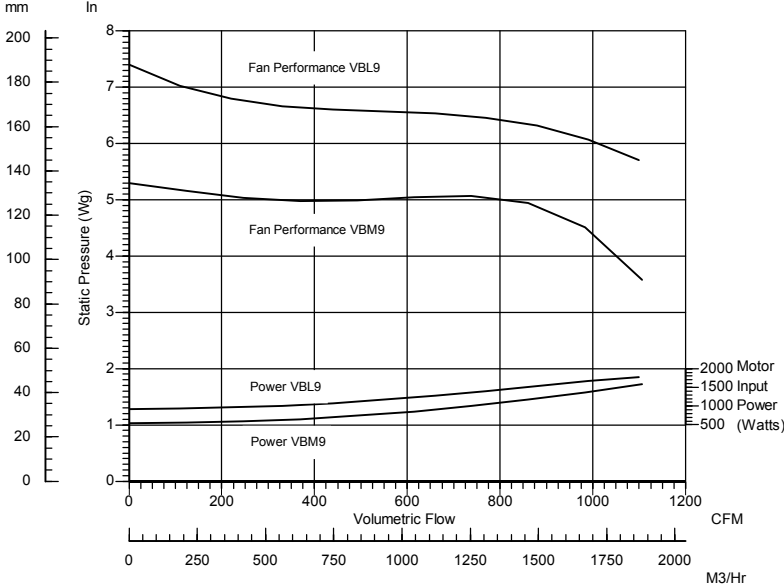

Motor type:	Squirrel cage induction motor IP55 as std
Nominal supply:	380/420VY / 200/240VD 3Ph 50Hz 440/480VY / 250/280VD 3Ph 60Hz
Ancillaries:	Inlet and discharge guards, inlet filters, spigots
Materials:	Fan case: cast aluminium LM6 Impellers: galvanised sheet steel
Finishes:	Stove enamel as std
Mounting:	Motor feet or pedestal
Noise levels:	92 dB(A) Free Air, 1 metre
Weight:	28Kg for 2 pole unit
Variations:	Increased safety to ATEX std available

Outline dimensions:

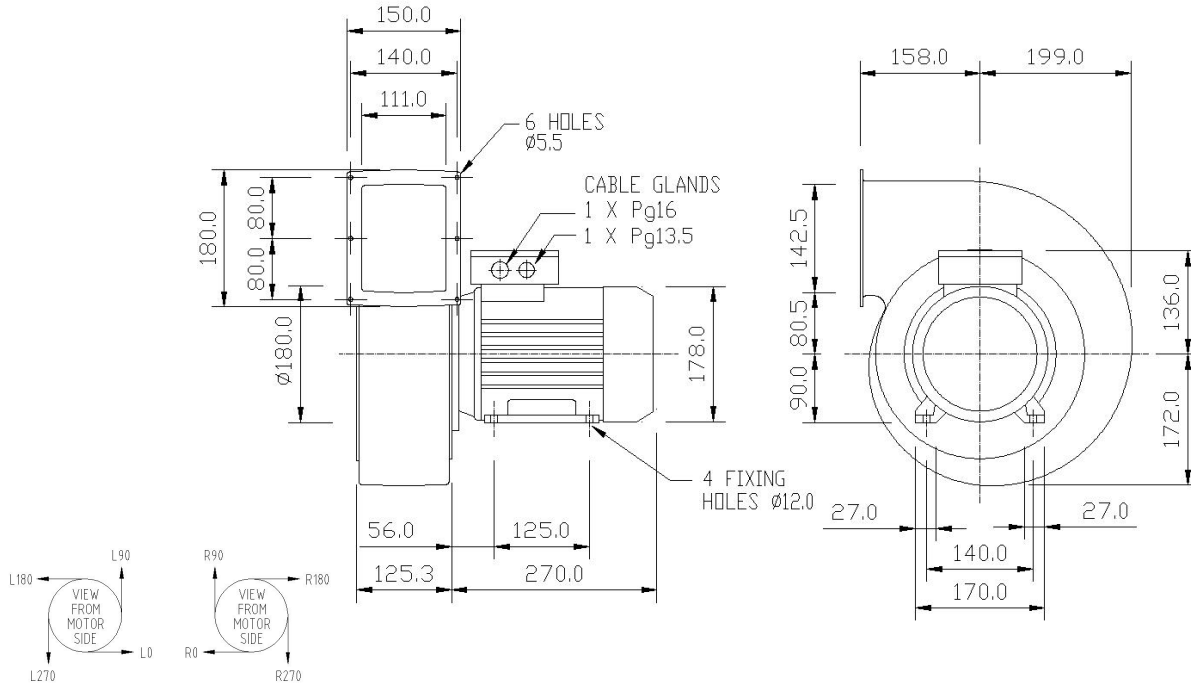

Please note (1) - all drawings measurements are in millimeters (mm)
Please note (2) - above technical specifications are subject to change

AIR CONTROL INDUSTRIES LTD.
 Weycroft Avenue, Millwey Industrial Estate, Axminster, EX13 5HU
 Tel: 0845 5000 501, Fax: 0845 5000 502

AIR CONTROL INDUSTRIES INC.
 76 Augusta Rockland Road, Windsor, ME 04363, USA
 Tel: 207-445-2518, Fax: 207-445-2497

www.aircontrolindustries.com / sales@aircontrolindustries.com

Ref: Centrifugal VBL9/VBM9 Iss 10/2



Certificate No. FM20497