



Air Control Industries

# centrifugal VBM5

## Single Inlet Centrifugal Fan

ACI - Effective Air is our Business

### Performance details:

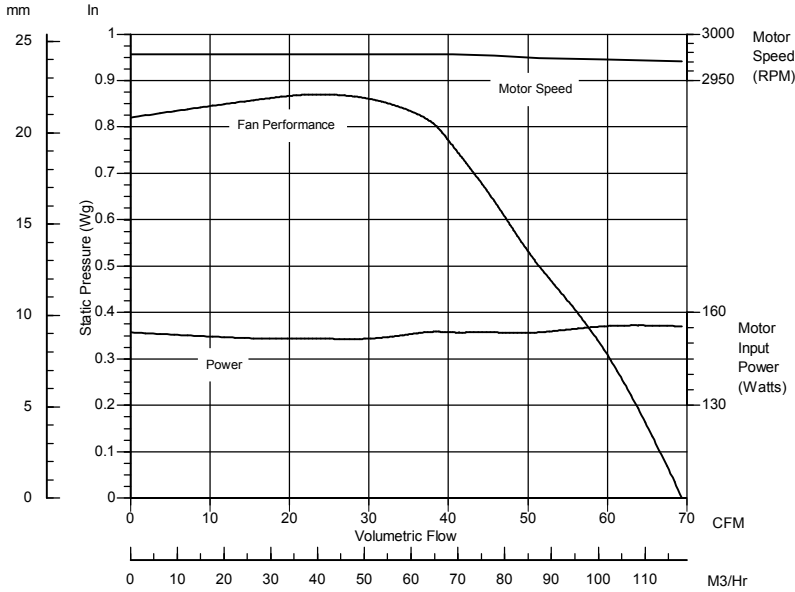
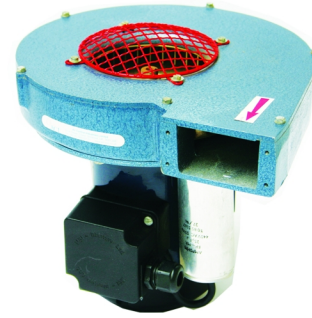

<b>Motor type:</b>	Squirrel cage induction motor IP44 as std, IP55 available
<b>Nominal supply:</b>	220/240V or 115V 1Ph 50/60Hz 380/420VY / 220/240VD 3Ph 50Hz 440/480VY / 250/280VD 3Ph 60Hz
<b>Ancillaries:</b>	Inlet and discharge guards, inlet filters, spigots
<b>Materials:</b>	Fancase: cast aluminium LM6 Impellers: galvanised sheet steel
<b>Finishes:</b>	Stove enamel as std
<b>Mounting:</b>	Motor feet or pedestal
<b>Noise levels:</b>	72.7dB(A) Free Air, 1 metre
<b>Weight:</b>	3.6Kg
<b>Variations:</b>	Increased safety to ATEX std available

### Outline dimensions:

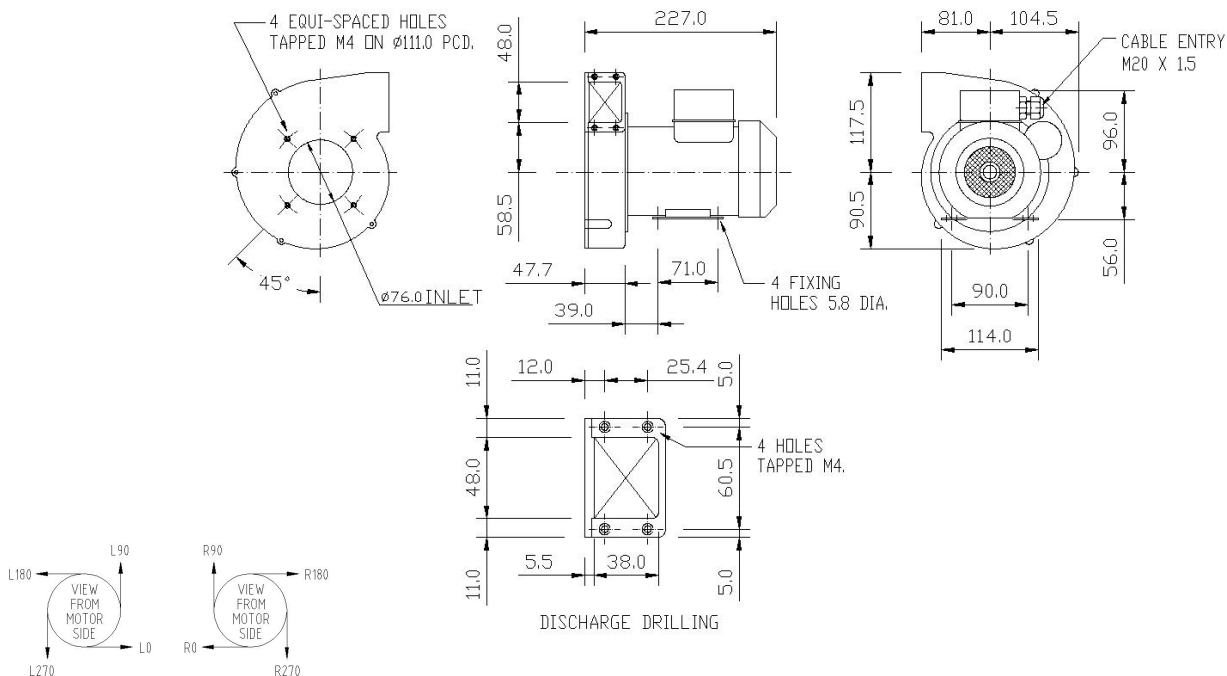

**Please note (1)** - all drawings measurements are in millimeters (mm)  
**Please note (2)** - above technical specifications are subject to change

**AIR CONTROL INDUSTRIES LTD.**  
 Weycroft Avenue, Millwey Industrial Estate, Axminster, EX13 5HU  
 Tel: 0845 5000 501, Fax: 0845 5000 502

**AIR CONTROL INDUSTRIES INC.**  
 76 Augusta Rockland Road, Windsor, ME 04363, USA  
 Tel: 207-445-2518, Fax: 207-445-2497

[www.aircontrolindustries.com](http://www.aircontrolindustries.com) / [sales@aircontrolindustries.com](mailto:sales@aircontrolindustries.com)

Ref: Centrifugal VBM5 Iss 10/1



Certificate No. FM20497