

Centrifugal Fan VBL9

Single Inlet Centrifugal Fan

General Characteristics:



Motor type:	Squirrel cage induction motor IP55 as std
Nominal supply:	380/420VY / 200/240VD 3Ph 50hz 440/480VY / 250/280VD 3Ph 60Hz
Ancillaries:	Inlet & discharge guards, Inlet filters, Spigots
Materials:	Fancase: Cast aluminium LM6 Impellers: Galvanised sheet steel
Finishes:	Unpainted or stove enamel (black) as std
Mounting options:	Motor feet or Pedestal
Noise levels:	95dB(A) Free Air, 1M
Weight:	22Kgs / 49Lbs
Motor Variations:	ATEX, CE, CSA, UL available

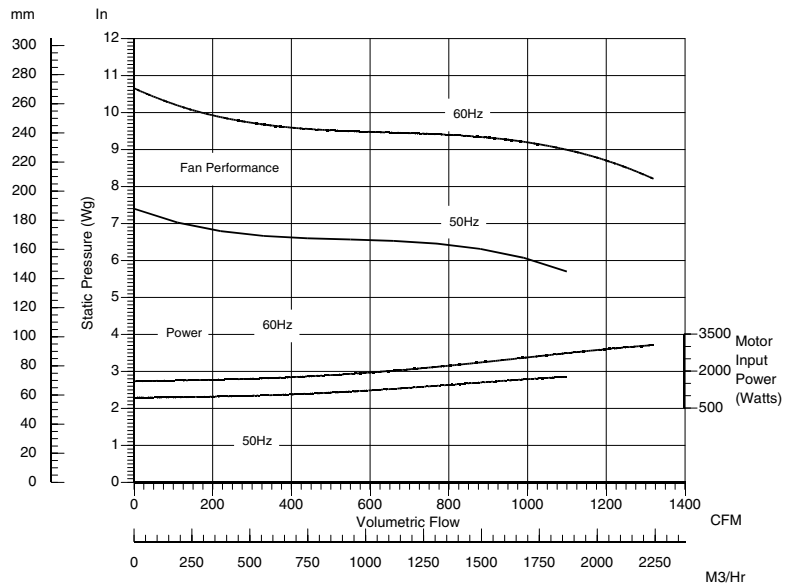

Outline dimensions:

[Note: motor shown is for 50Hz performance.
Motor dimensions for 60Hz operation may vary]

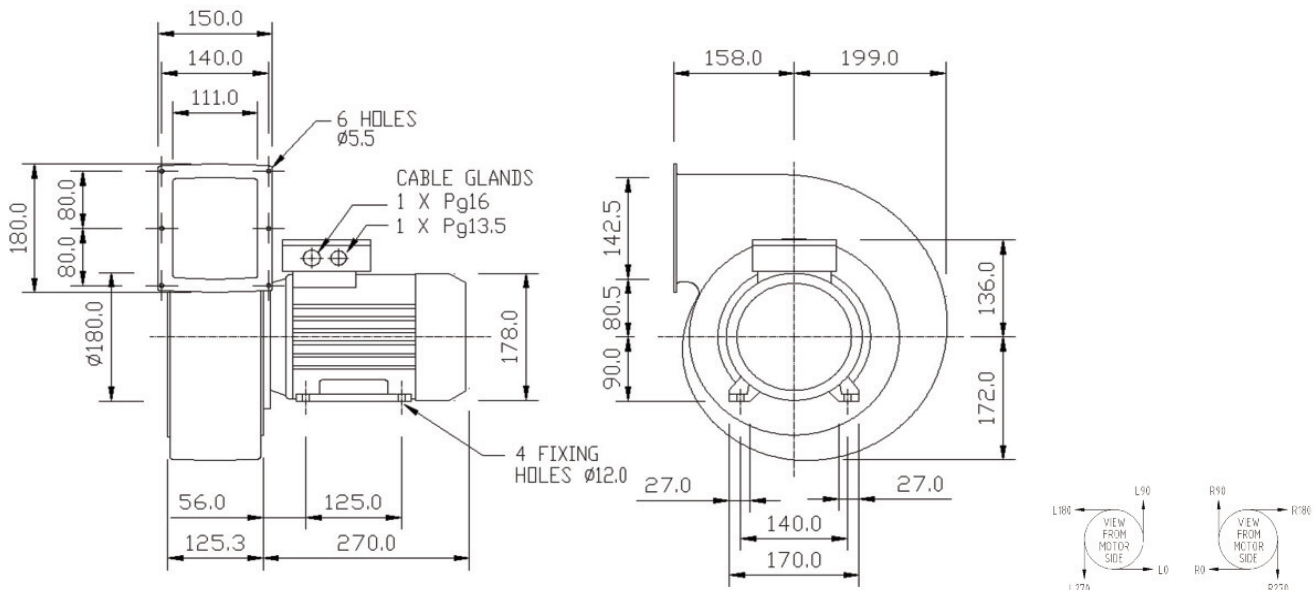

Air Control Industries

Ref: CENT VBM9 2011/V1

Please note (1) - all drawings measurements are in millimeters (mm)
Please note (2) - above technical specifications are subject to change

AIR CONTROL INDUSTRIES LTD
Weycroft Avenue, Millwey Industrial Estate
Axminster, Devon, EX13 5HU
t: 0845 5000 501 f: 0845 5000 502
e: sales@aircontrolindustries.com
w: www.aircontrolindustries.com

AIR CONTROL INDUSTRIES INC
76 Augusta Rockland Road
Windsor, Maine, ME 04363
t: 207 445 2518 f: 207 445 2497
e: aciinc@aircontrolindustries.com