

Multi Stage MSX

Backward Curved, Single Inlet Centrifugal Fan

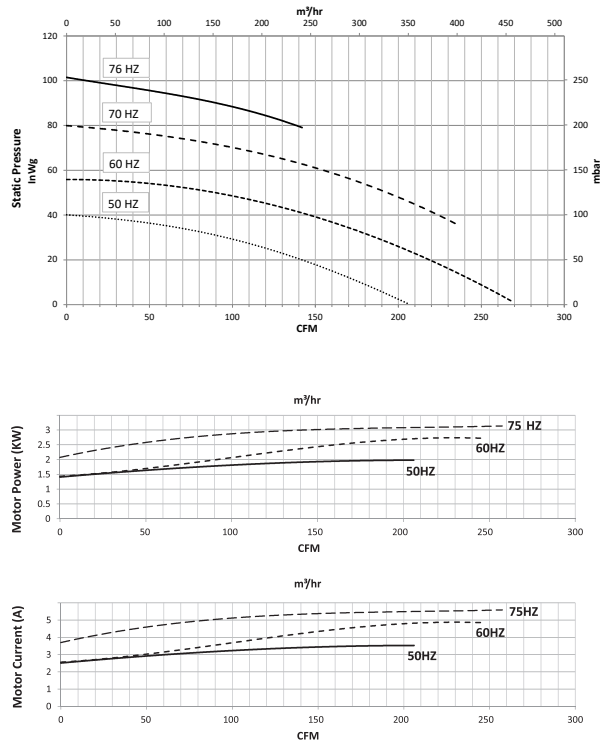
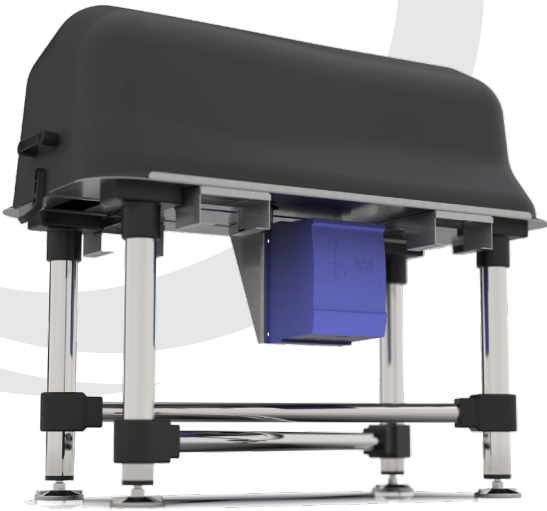

Please note:

1. Performance graphs show data tested to BS EN ISO 5801:2017 standard and represent typical 50Hz motor speed.
2. Imagery may not be representative of the unit supplied.
3. Motor electrical lead not shown.

Motor type: 3Kw, 2 Pole Motor
Nominal supply: 400/480 V, 3 Ph, 50/60 Hz
Bearings: Ball type, lubricated for life
Noise: Up 76.8 dB(A) @75Hz

Materials: Inlet & Fanscrolls: Cast Aluminium
 Impellers: Aluminium 1200 H14
 Stators: White polyester resin
 Baseplate & Leg Kit: Stainless Steel 304
 Enclosure Cover: ABS R59

Outline Dimensions

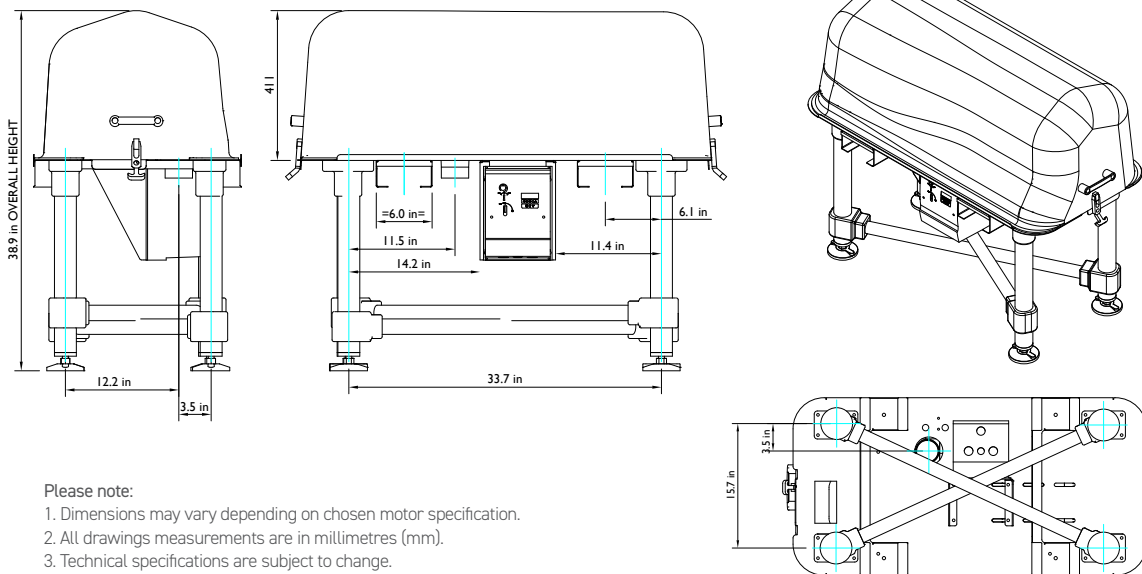

Please note:

1. Dimensions may vary depending on chosen motor specification.
2. All drawings measurements are in millimetres (mm).
3. Technical specifications are subject to change.
4. Outer body of motor rotates during operation.



AIR CONTROL INDUSTRIES
 shaping air movement since 1969

E: sales@aircontrolindustries.com
 W: www.aircontrolindustries.com