

# Bottle & Can Drying Systems

ACI's DRI-Line Series is a collection of drying systems specifically designed for the Global Food & Beverage Industries. Current users include leading producers and fillers of household names and brands, as well as some principal OEM's of turnkey filling lines and equipment.



The DRI-Line Series is a proven drying solution for filling line speeds from 100's to 1000's of bottles or cans per hour and provides an efficient and effective drying for cans prior to ink jet coding, glass/PET bottles pre-labelling, and removing all moisture prior to packing. In addition it has been specifically designed to minimise running costs as well as lessen operational and maintenance issues.



## Drying System Options: 'LNL' (Low Noise Level)

- Premium drying solution with both the blower and the air delivery device(s) housed within a robust stainless steel enclosure
- Noise levels below 85dB(A)



## 'EL' (Eye Level) Drying System

- Semi-enclosed unit where the blower is contained within a Stainless Steel Enclosure
- Additional protection to the blower is given by mounting the enclosure to a leg kit (1750mm high) that can be easily positioned



## 'RM' (Remote Blower) Drying System

- A totally 'open' unit with no acoustic or spray containment supplied
- Systems consist of a blower, ducting, and the method of air delivery only

## 'DS' (DRI-Spot) Drying System

- Low cost, economic and effective 'trouble-shooter' system for drying specific areas of either bottles or cans at relatively low speeds

# Bottle & Can Drying Systems

Not content with offering customers just Air Knife Technology, ACI has developed other bespoke products for drying bottles and cans.

## ACI JetPlates:

- Improved drying performance
- Simple installation - JetPlates act as guides
- Air is delivered at high velocity very close to the bottles
- Once fitted, little or no adjustment is necessary
- Choice of Slot configurations to suit application

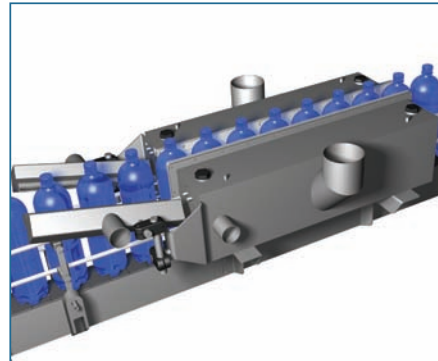

## ACI Can Drying Tunnels:

- Water dispersed by innovative slot design
- Design produces less turbulence, and is quieter than conventional Airknife solution
- Tunnels contain all spray, and can be simply adjusted by one operator
- Tunnel construction acts as an acoustic enclosure
- Tunnels constructed from polypropylene sheet with a stainless steel plenum
- Can be applied to single or multi lane conveyor lines



## ACI Air Knives:

- Time proven method for delivering blower-driven air to product
- Can be supplied in either Stainless Steel or Anodised Aluminium
- Can be used on their own or with JetPlates to provide high velocity air over a complete bottle

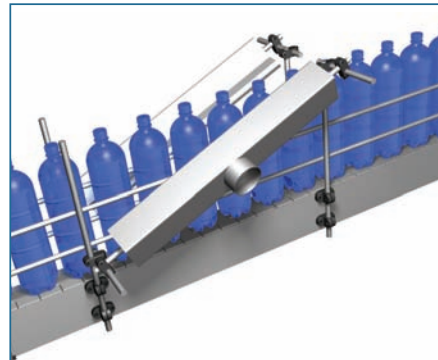

## ACI Cap & Neck Dryers:

- Particularly effective for problem areas on unusual bottle shapes, bottle necks, and shrink wrapped products

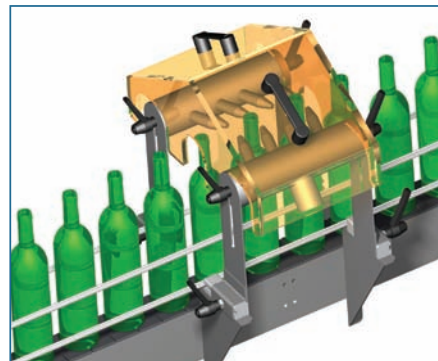

### Air Control Industries Ltd

Weycroft Avenue, Millwey Rise Industrial Estate,  
Axminster, Devon, EX13 5HU, United Kingdom  
Tel: +44(0)1297 529242 Fax: +44(0)1297 529241  
Email: sales@aircontrolindustries.com

[www.bottlecandrying.com](http://www.bottlecandrying.com)





**Air Control Industries**

## DRI-Line Series Air Knives

### **Air Knife Overview:**

ACI Air Knives are a proven drying solution for many applications within the Beverage and Filling Industries.



They can be used on their own, or used in conjunction with other ACI products such as JetPlate, Can Drying Tunnels Neck and Cap dryers.

The benefits of ACI Air Knives include their ability to deliver a continuous curtain of air at an even pressure over the whole product. In addition angled adjustment permits air delivery to be varied to maximise efficiency according to the product dimensions.

### **Stainless steel (304 or 316) Air Knives**

Air Knives commonly employed in the Food and Beverage Industry and will therefore be regularly subjected to thorough clean down operations.

ACI are therefore able to offer Air Knives fabricated from either 304 or dairy standard 316 Stainless Steel, a material which can readily withstand these sorts of environment.

All of ACI's air knife designs can be readily adapted to suit specific individual customer needs.

- Material Stainless Steel 304 S11 1-4307 BSI449
- Various mounting and inlet configurations available
- Air Knife lengths available in 10mm increments
- Alternative positions for inlets available

**Anodised Aluminium Air Knives** can also be supplied and adapted to suit individual customer needs. Although this material does not have the same hard wearing characteristics of Stainless Steel, they can still be a cost-effective solution for many Food and Beverage applications.

**Drying Systems for the Filling Industry**  
[www.bottlecandrying.com](http://www.bottlecandrying.com)



**Air Control Industries**

# DRI-Line Series Air Knives

**Air Knife outline drawing (Stainless Steel):**

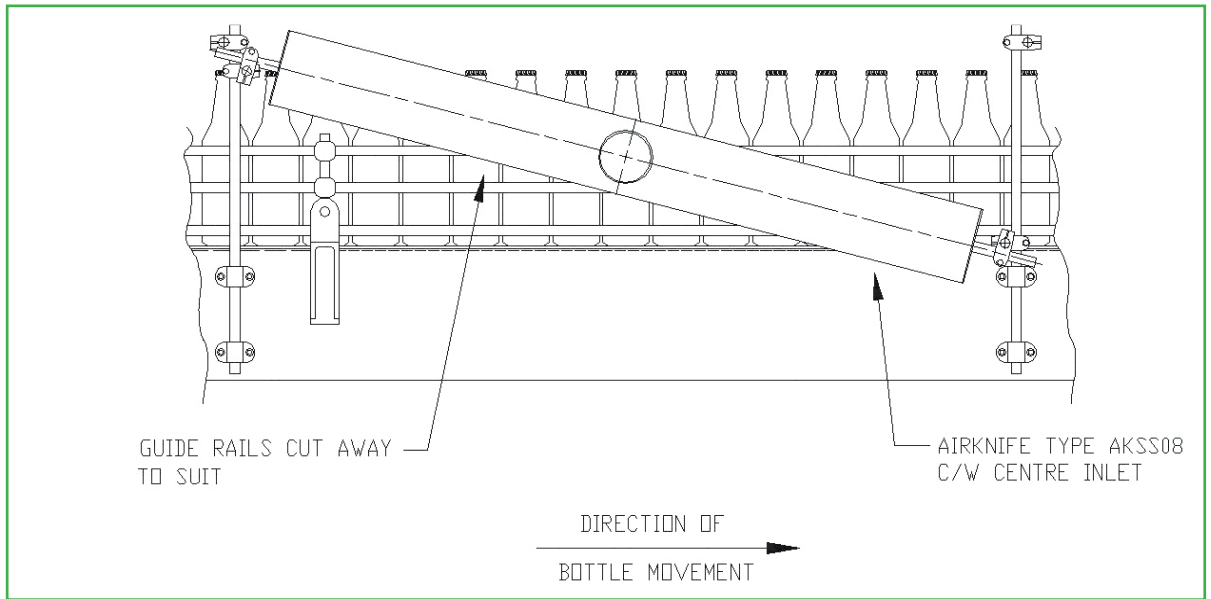

**Air Knife & JetPlate outline drawing:**

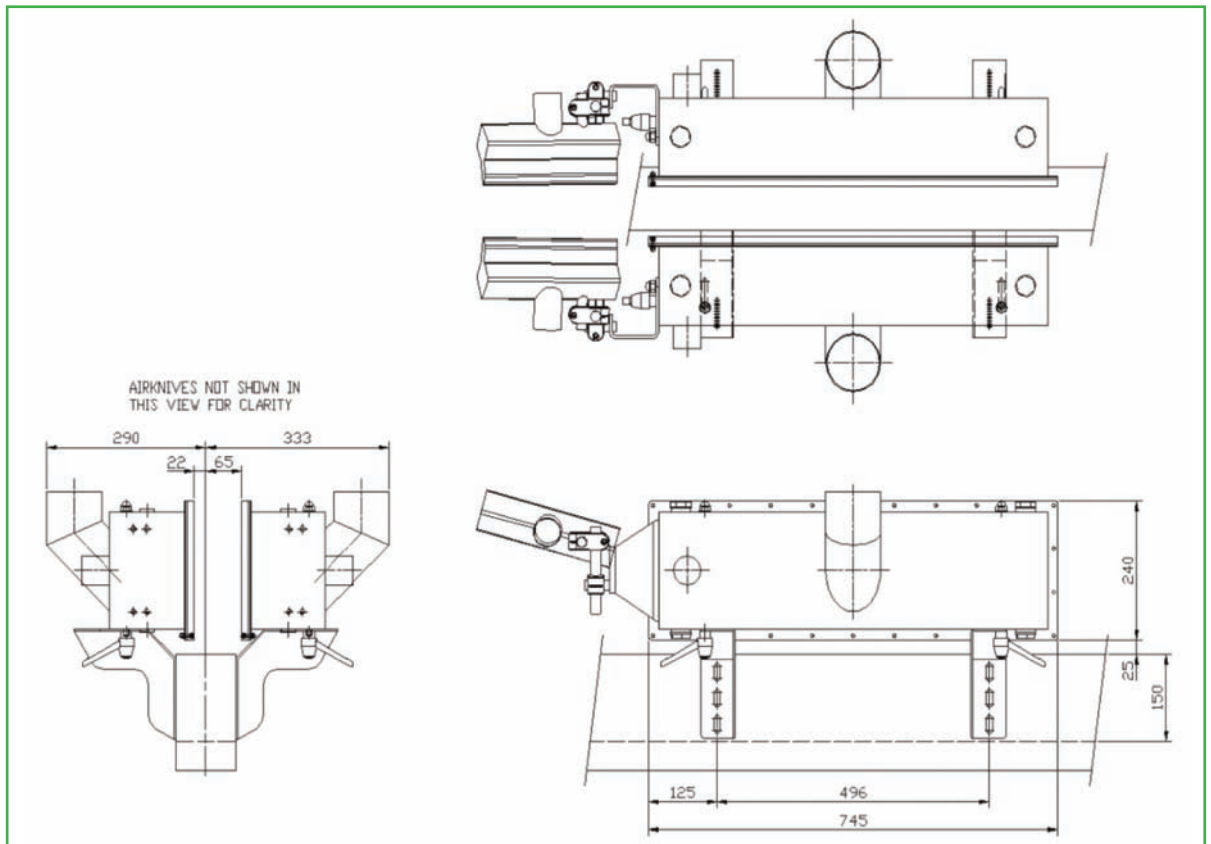

Ref: DRI-Line DS 2014/V1

**Please note (1)** - all drawings measurements are in millimeters (mm)  
**Please note (2)** - above technical specifications are subject to change

**Air Control Industries Ltd**  
Weycroft Avenue, Millwey Rise Industrial Estate,  
Axminster, Devon, EX13 5HU, United Kingdom  
Tel: +44 (0)1297 529 242 Fax: +44 (0)845 5000 502  
Email: sales@aircontrolindustries.com

www.bottlecandrying.com



**Air Control Industries**

# DRI-Line Series JetPlates

## JetPlate Overview:

Derived from ACI Air Knife Technology, JetPlates have been purposely designed to improve the efficiency of ACI's Drying Systems whilst also simplify installation and on-site maintenance.

The benefits and features of ACI's JetPlates include:

- When compared to standard Air Knives, JetPlates deliver twice the volume of high pressure air over product
- The design of the JetPlates allows for the blower-driven air to be delivered within 3mm of the product. This is because the faceplate acts as the conveyor guide rail.
- The slot design incorporated into the JetPlates enables all moisture to be directed downwards and away from the conveyor line, thereby preventing any recontamination.
- The installation of Jetplates simplifies installation, maintenance and operation processes.
- The Jetplate design requires no pitch adjustment to achieve optimum drying performance.

### Configurations:

JetPlates are available with a number of slot designs and plenum sizes. These are completely dependant on factors such as the bottle shape and size, speed of the line and the nature of the label type being applied.

JetPlates can also be used in conjunction with Air Knives and/or cap and neck dryers. This configuration will again be determined by factors dictated by the application.

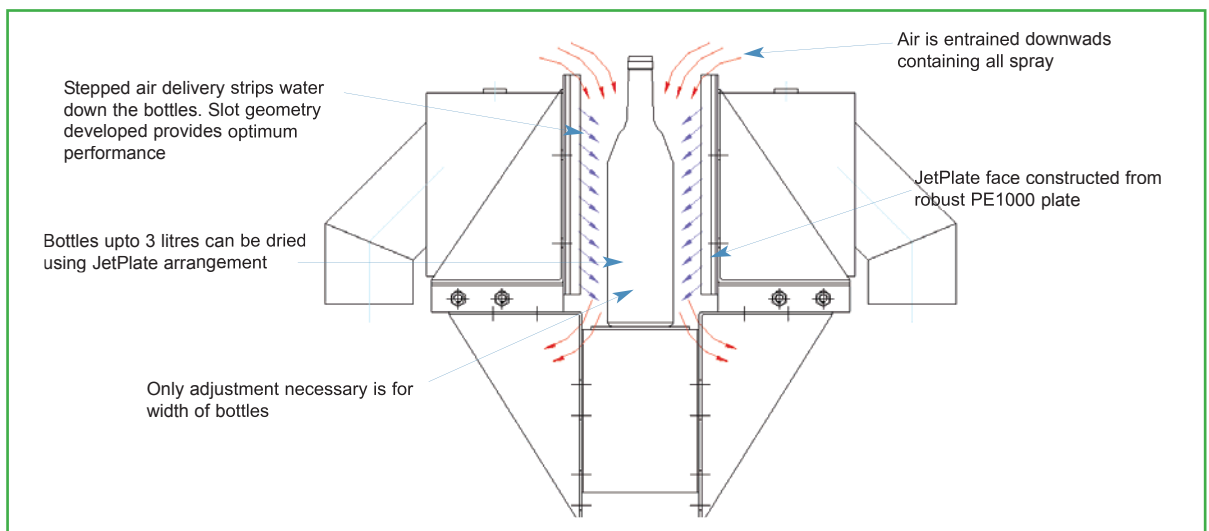
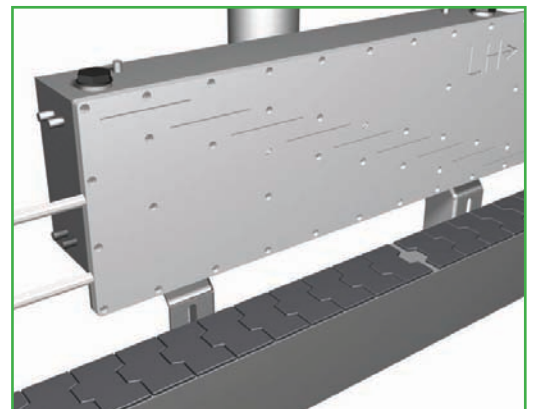
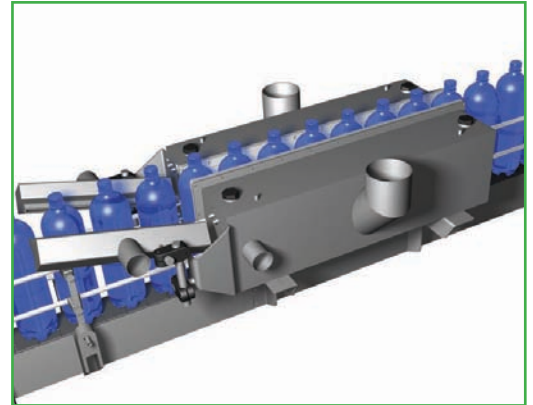

**Drying Systems for the Filling Industry**  
[www.bottlecandrying.com](http://www.bottlecandrying.com)



**Air Control Industries**

# DRI-Line Series JetPlates

**Jetplate and Air Knife outline drawing:**

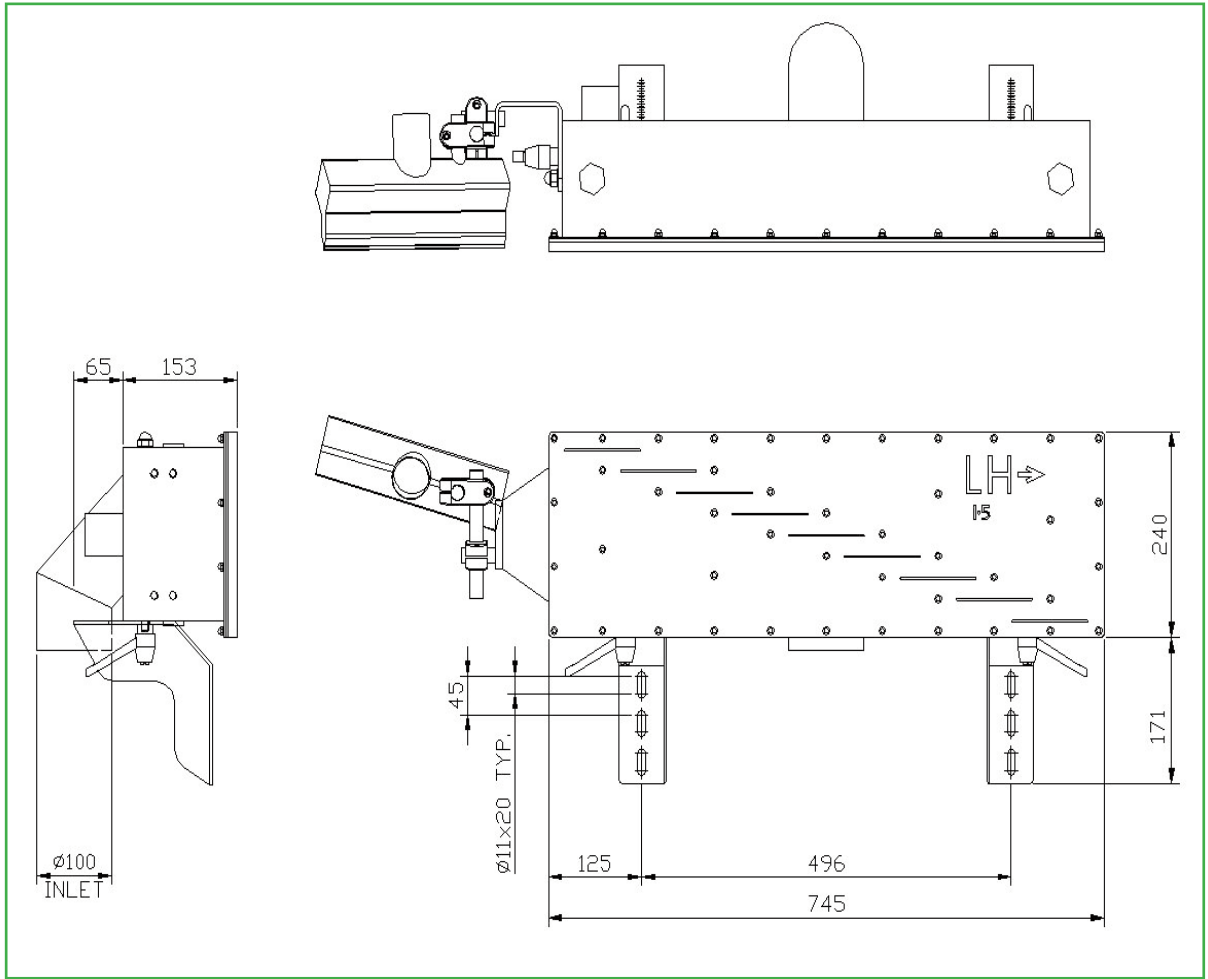

www.bottlecandrying.com



### JetPlate mountings:

- JetPlates will be supplied with a set of mounting brackets that will need to be directly attached to the existing conveyor (fixings are not supplied as standard).
- JetPlates will need to be mounted so that the slots of the dryer are in line with, and close to the neck of the product being dried.
- JetPlates can be moved to suit various sizes of product by simple 'slide' adjustment.



Ref: DRI-Line DS 2014/V1

**Please note (1)** - all drawings measurements are in millimeters (mm)  
**Please note (2)** - above technical specifications are subject to change

### Air Control Industries Ltd

Weycroft Avenue, Millwey Rise Industrial Estate,  
Axminster, Devon, EX13 5HU, United Kingdom  
Tel: +44 (0)1297 529 242 Fax: +44 (0)845 5000 502  
Email: sales@aircontrolindustries.com



**Air Control Industries**

## DRI-Line Series Other Drying Methods

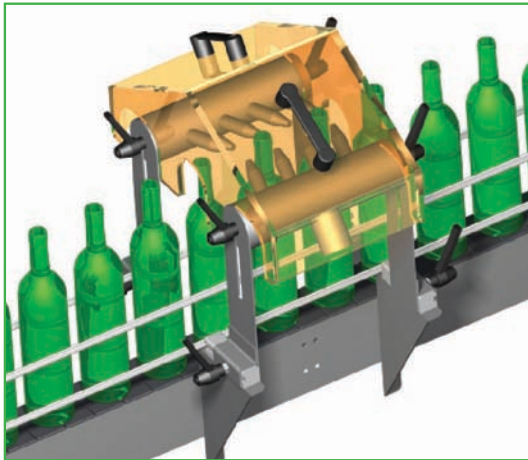

### **Crown Cap Dryer**

ACI's Bottle Cap Dryer is a nozzle manifold specifically designed to target and remove water from the crown cap area of glass bottles to prevent and reduce the possibility of corrosion and contamination.

The Bottle Cap Dryer design includes:

- Two stainless steel (314) manifolds with 4 discharge nozzles (each nozzle is  $\varnothing 9\text{mm}$ )
- A clear Makralon splash cover fitted with handle

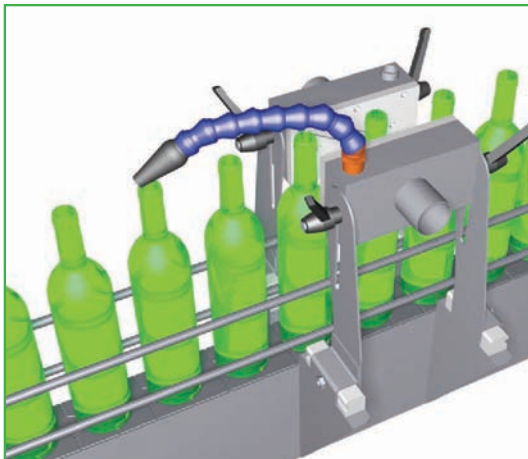

### **Neck Dryer**

ACI's Neck Dryer is specifically intended for the drying of wine bottle necks so that labels will adhere effectively.

The design comprises of two stainless steel plenums, with a JetPlate discharge made from PE1000. Each plate has two slots of  $100 \times 1.5\text{mm}$  and a pre-determined slot pattern, allowing air to remove liquid from the product. The brackets that are supplied with this unit also allow for easy movement and adjustment.

The Neck Dryer fits over existing conveyor guide bars so no modification required. The unit can be adjusted to suit various sizes of product by modifying the position of the supplied brackets.

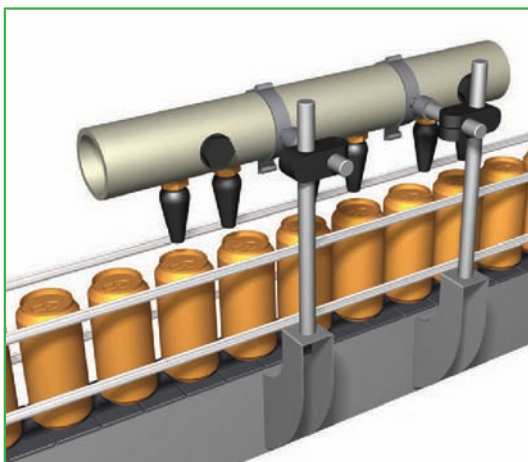

### **'Spider' Nozzle Manifold**

ACI's 'Spider' Manifold is a nozzle arrangement designed to target specific problem areas such as under crown caps, the necks of wine or beer bottles.

The 'Spider' Manifold includes:

- A polypropylene manifold with up to 10 PDM nozzles
- A stainless steel and polyimide cantilevered clamp kit

**Drying Systems for the Filling Industry**  
[www.bottlecandrying.com](http://www.bottlecandrying.com)



Air Control Industries

# DRI-Line Series Other Drying Methods

www.bottlecandrying.com

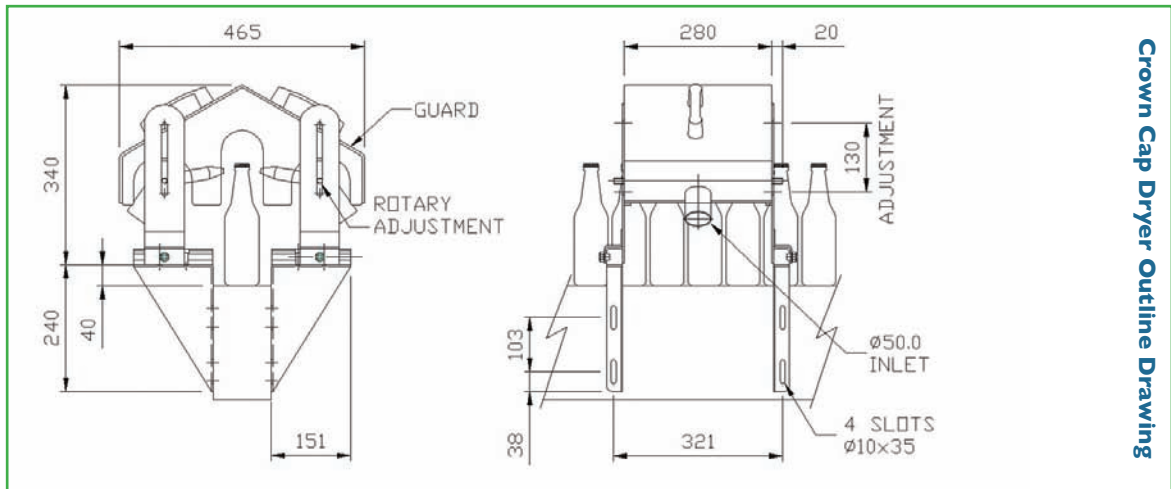

Crown Cap Dryer Outline Drawing

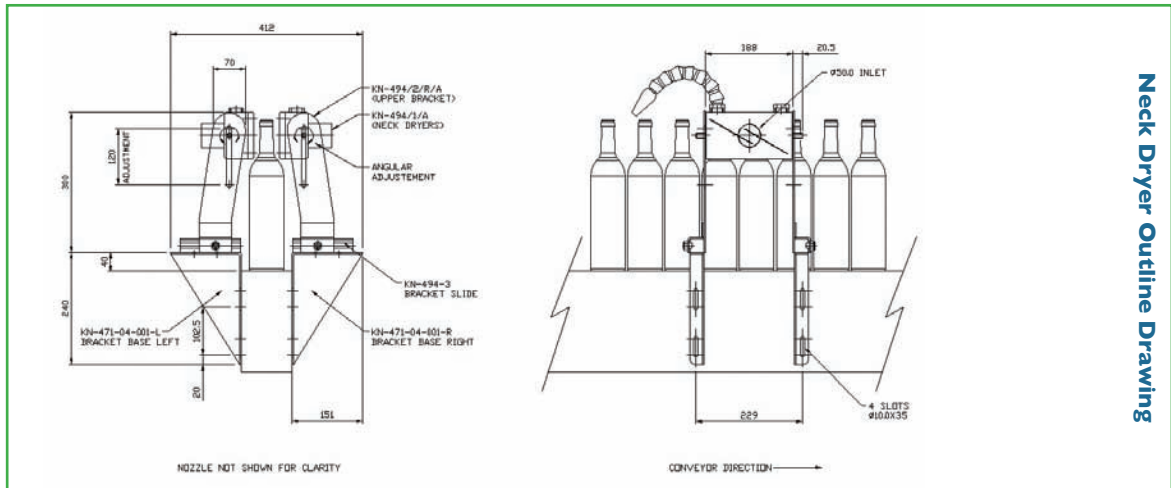

Neck Dryer Outline Drawing

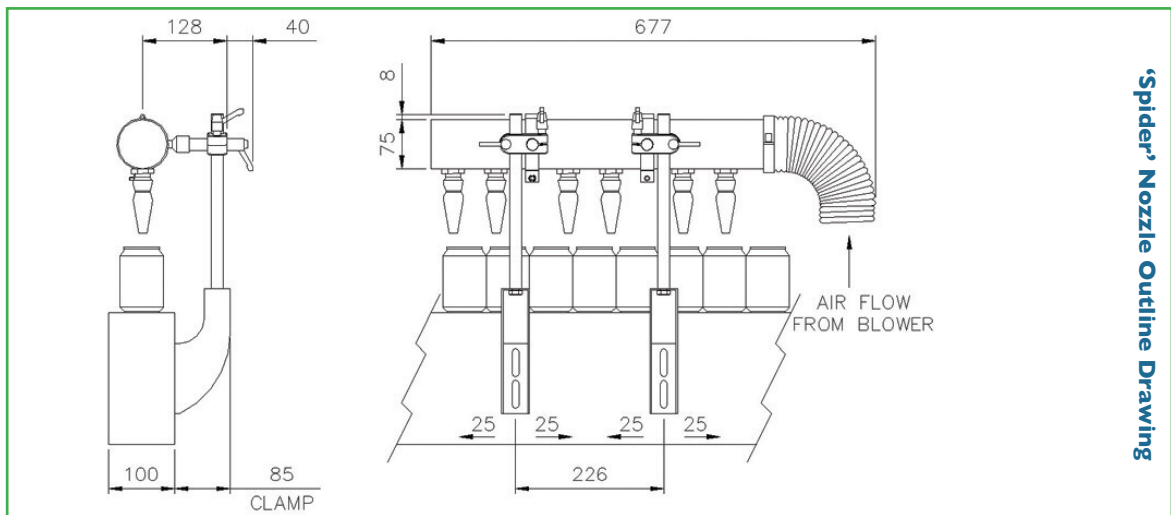

'Spider' Nozzle Outline Drawing

Ref: DRI-Line DS 2014/V1

**Please note (1)** - all drawings measurements are in millimeters (mm)  
**Please note (2)** - above technical specifications are subject to change

Air Control Industries Ltd  
Weycroft Avenue, Millwey Rise Industrial Estate,  
Axminster, Devon, EX13 5HU, United Kingdom  
Tel: +44 (0)1297 529 242 Fax: +44 (0)845 5000 502  
Email: sales@aircontrolindustries.com



**Air Control Industries**

# DRI-Line Series Can Drying Tunnels

Available in both single and multi-lane configurations, ACI's tunnel-based can drying system features specially configured slots that direct air to remove water efficiently whilst driving it downwards and out of the enclosed area.

Operating in an enclosed chamber ensures the drying blower-delivered air operates more efficiently than with conventional 'open' systems.

In addition, the enclosed environment ensures the water is contained and not dispersed into the working environment. Noise attenuation is another benefit of the enclosed design.

**Benefits include:**

- All water spray contained and noise reduced
- Simple & quick to install
- Simple single operator adjustment for different can heights
- Easy to clean and maintain
- Permits height adjustments to process different can heights
- Water dispersed by innovative 'Y' shaped slot design
- Design produces less turbulence, lower noise than conventional
- Air Knife solutions - use low pressure air (20-30mBar)
- Can be applied to single or multi lane conveyor lines

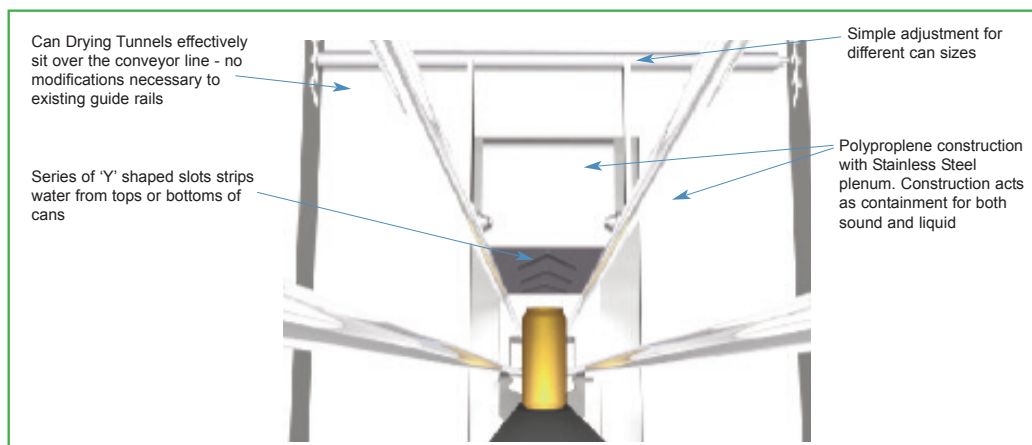

**Drying Systems for the Filling Industry**  
[www.bottlecandrying.com](http://www.bottlecandrying.com)



**Air Control Industries**

# DRI-Line Series Can Drying Tunnels

www.bottlecandrying.com



**Standard Construction:**

The Can Drying Tunnel is constructed from polypropylene with a stainless steel plenum and adjustment plate. The tunnel acts as a baffle plate for both sound and liquid.

**Standard Dimensions:**

ACI's Can Drying Tunnels are available in a number of different configurations depending on parameters such as the speed of conveyor line and the area of the can that is required to be dried.

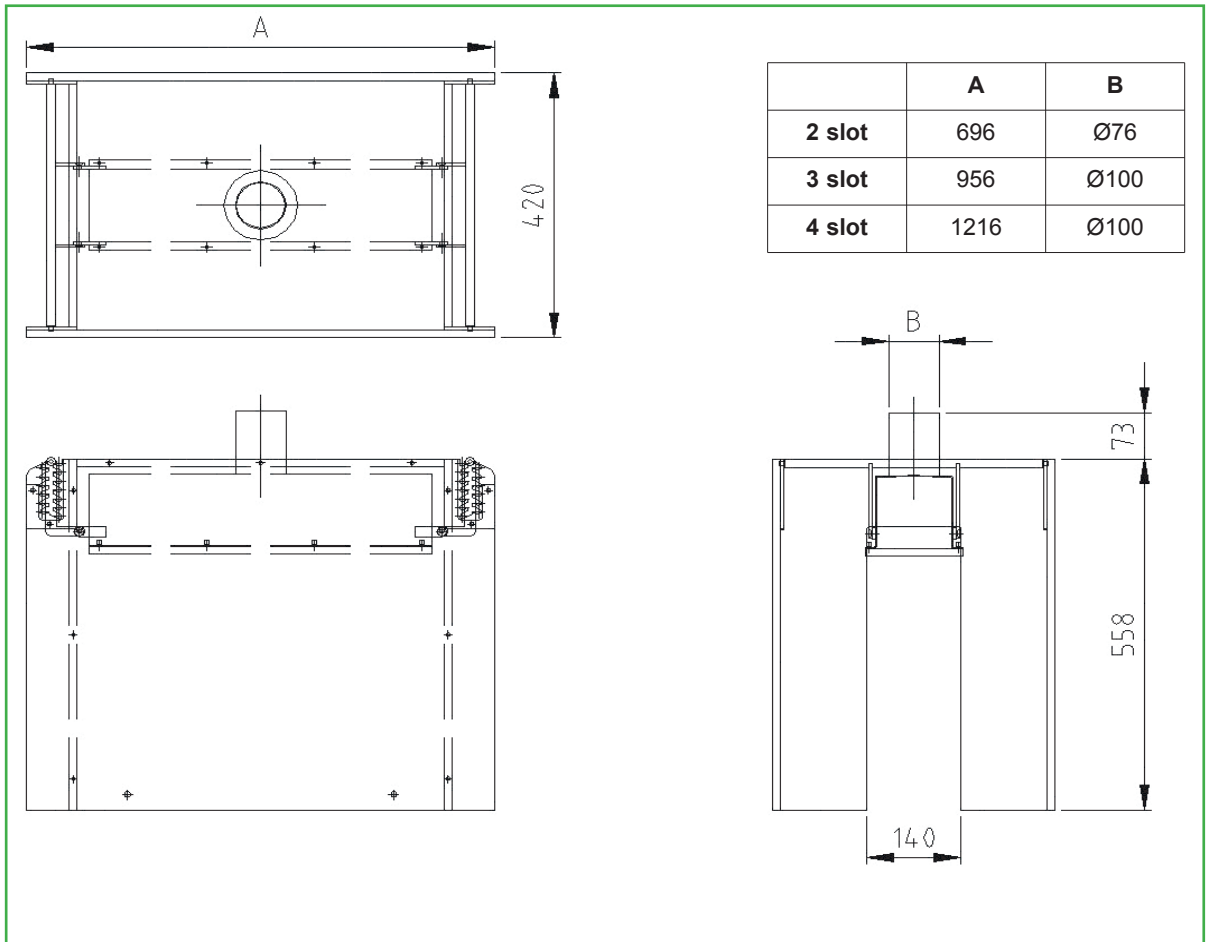

Ref: DRI-Line DS 2014/V1

**Please note (1)** - all drawings measurements are in millimeters (mm)  
**Please note (2)** - above technical specifications are subject to change

**Air Control Industries Ltd**  
Weycroft Avenue, Millwey Rise Industrial Estate,  
Axminster, Devon, EX13 5HU, United Kingdom  
Tel: +44 (0)1297 529 242 Fax: +44 (0)845 5000 502  
Email: sales@aircontrolindustries.com



**Air Control Industries**

## 'C-TSB' - Complete Can Drying System

<b>Configuration</b>	Complete Can Drying System
<b>Product Category</b>	All cans
<b>Application Area</b>	Drying can tops, bottoms, and sides without twisters

ACI's 'C-TSB' Can Drying Systems effectively dries can tops, sides and bases within a total conveyor length of less than 2.5metres (8.2ft). Using innovative JetPlate technology and blower driven air, this system is suitable for processing whole cans at speeds in excess of 75,000 units per hour without the need to twist, thereby saving valuable space on the can filling line.

"C-TSB' outline drawing (shown with optional acoustic/spray enclosure)

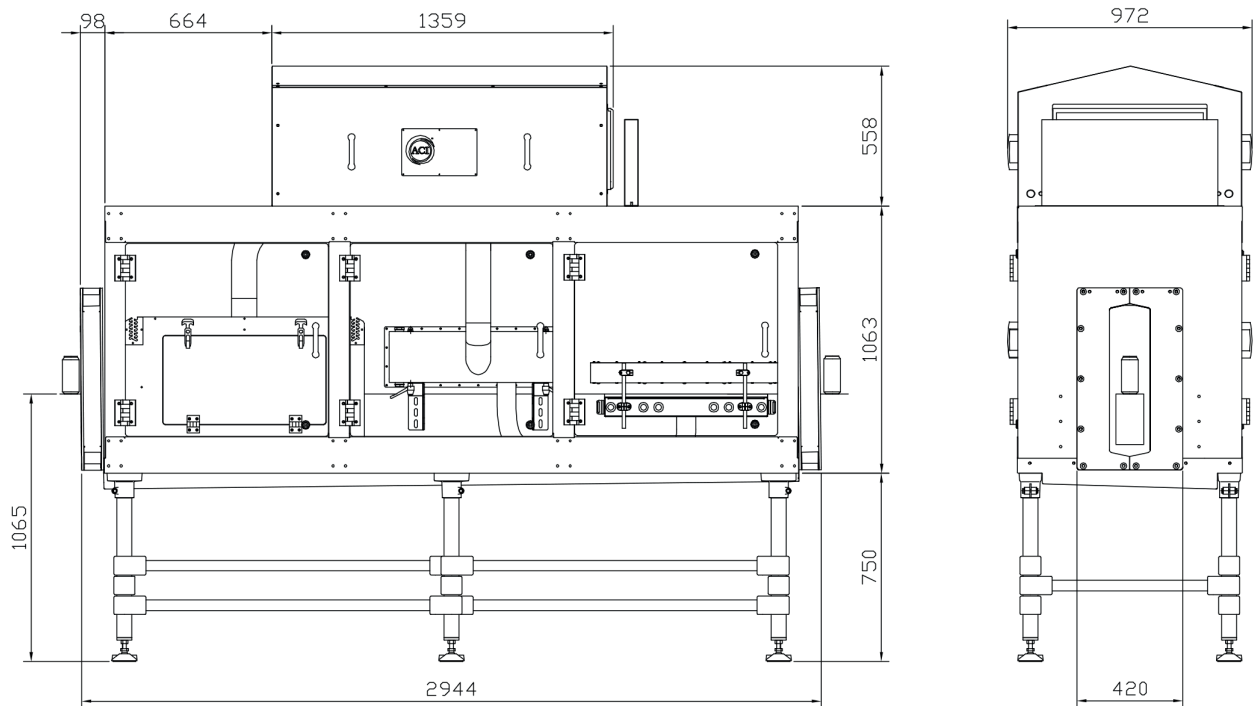

ACI's EPI10A compact blower provides the airflow for the system which typically is supplied within an acoustic enclosure mounted to the side or above the filling line.

The system is simple to install, operate and maintain and can readily cope with different can heights and diameters.

Further benefits of this system include:

- minimises overspray
- all removed liquids can be captured and either recycled or alternatively channelled into any waste water system

[www.bottlecandrying-us.com](http://www.bottlecandrying-us.com)



**Air Control Industries**

# 'C-TSB' - Complete Can Drying System

www.bottlecandrying-us.com

'C-TSB' outline drawing:

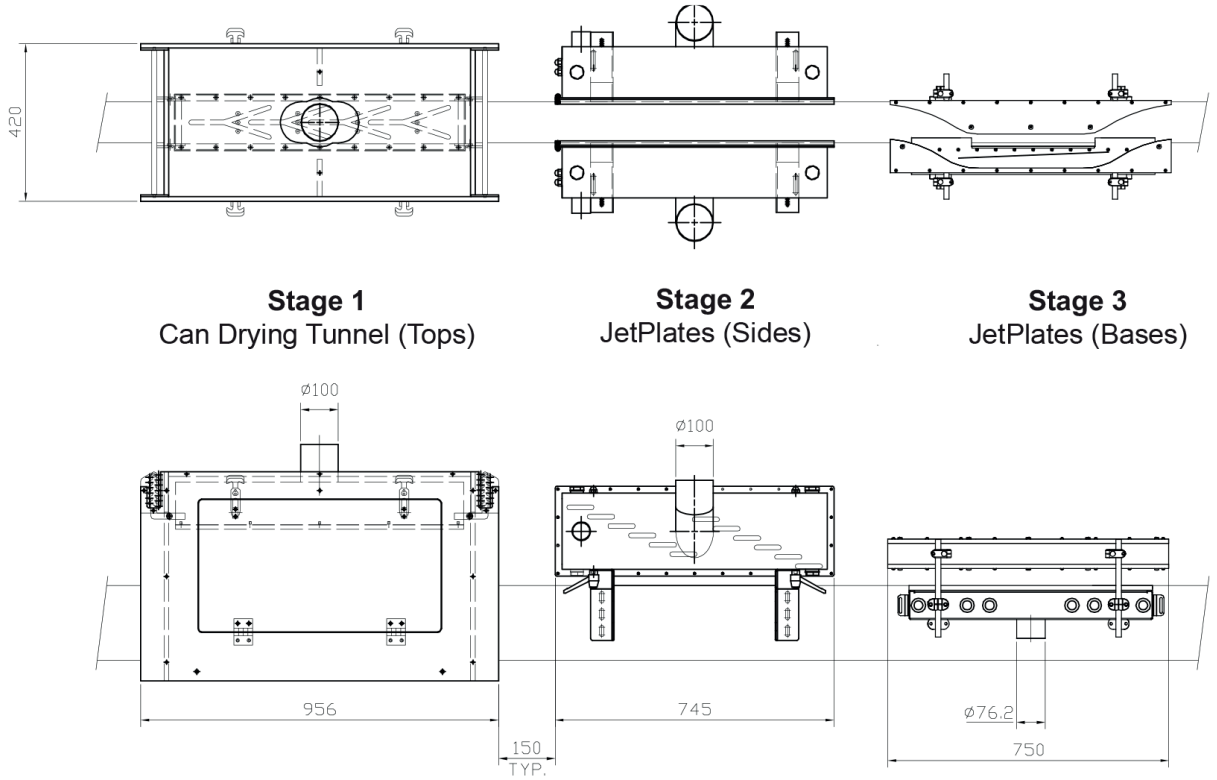

This system can be broken down into three distinctive stages.

### Stage 1 - Drying Can Tops

ACI's can drying system features specially configured 'Y' slots that direct blower-driven air to remove water/liquid efficiently from can tops whilst driving it downwards. All overspray is contained within the tunnel's polypropylene enclosure.

### Stage 2 - Drying Can Sides

A pair of ACI JetPlates enables the can sides to be thoroughly dried. Their faceplates have the benefit of acting as guide rails to passing cans, thereby allowing the airflow to act on the sides of the product from no more than 3mm.

### Stage 3- Drying Can Bottoms

A new under-can JetPlate has been designed for this stage which can be easily installed onto existing lines without the need to remove conveyor belts etc. Because of its innovative design, the under-can JetPlate utilises the 'Coanda Effect' which removes water downwards through a gap between the dryer and the side of the conveyor preventing re-wetting of the sides.

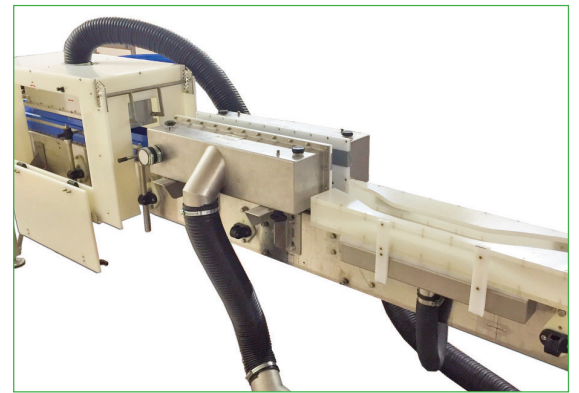

Please note (1) - all drawings measurements are in millimeters (mm)  
Please note (2) - above technical specifications are subject to change

Ref: DRI-Line Cb-C 2017 VI

**Air Control Industries Inc**  
76 Augusta Rockland Road,  
Windsor, Maine, ME 0436, USA  
Tel: 207-445-2518 Fax: 207-445-2497  
Email: aciinc@aircontrolindustries.com



**Air Control Industries**

## 'Cb-C' - Craft Brewery Can Drying System

<b>Configuration</b>	Craft Brewery Can Drying System
<b>Product Category</b>	All Cans (330-566ml)
<b>Application Area</b>	Drying can tops or bottoms, and sides

ACI's 'Cb-C' Craft Brewery Can Drying System is specifically designed to surface dry aluminum cans within craft and micro-brewery operations - whether drying for date coding or packaging. Using a small 5.5kW centrifugal, radial bladed blower, ACI's 'Cb-C' system is suitable for line speeds lower than 6,000 cans per hour and designed to be easily installed, operated and maintained. Noise levels are 87 dB(A) with the polyethylene spray cover and 90 dB(A) without. An additional acoustic enclosure is available for the blower, if required. These systems are capable of drying can sizes 330-568ml, providing a water removal efficiency figure of 98%, and are backed up with a 24 month warranty.

'Cb-C' illustrated:

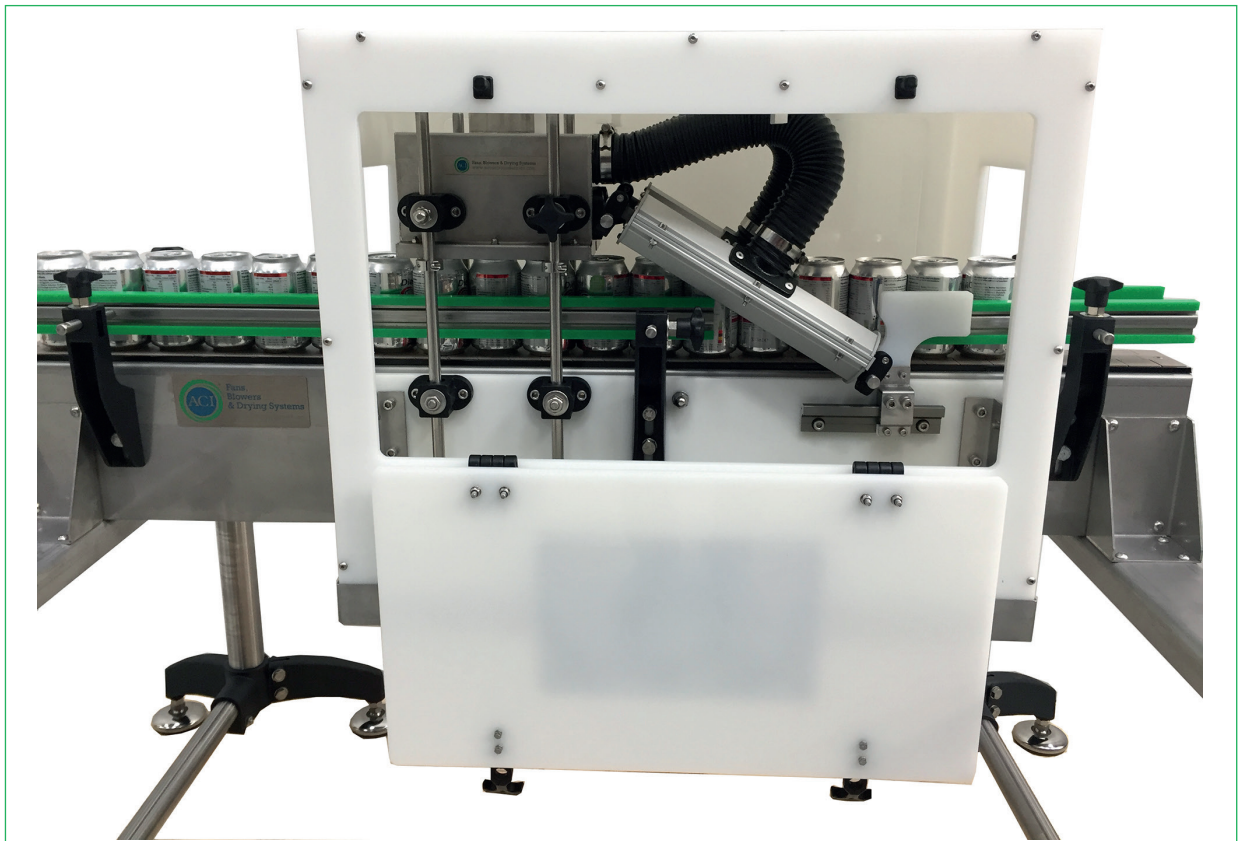

<b>'CB-C' Items</b>	<b>Quantity</b>
Stainless steel 'Y' slot drying plenum chamber	1
AK05 anodized aluminum air knives, 300mm long	2
Clamping kits	2
5.5kW Centrifugal Blower (Model APE 711)	1
Polyethelene Mounting Plates	2
Optional polyethelene cover	1
Flexible ducting	5m
Jubilee clips	2

**Drying Systems for Craft & Micro-Breweries**  
[www.bottlecandrying.com](http://www.bottlecandrying.com)



**Air Control Industries**

# 'Cb-C' - Craft Brewery Can Drying System

www.bottlecandrying.com

'Cb-C' outline drawing  
(Conveyor not included)

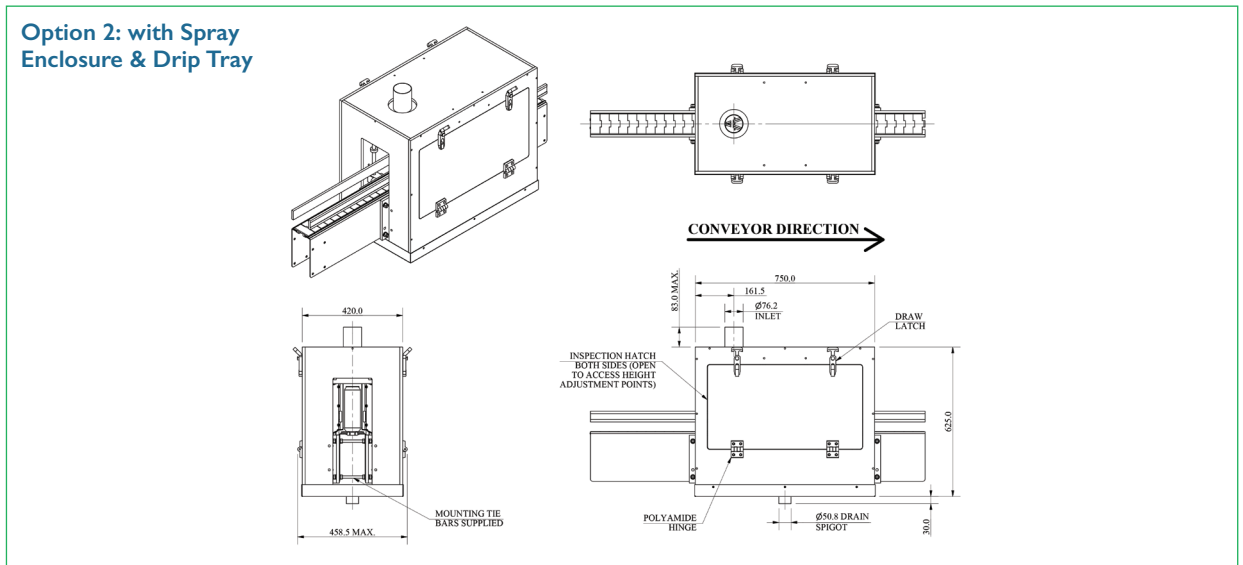
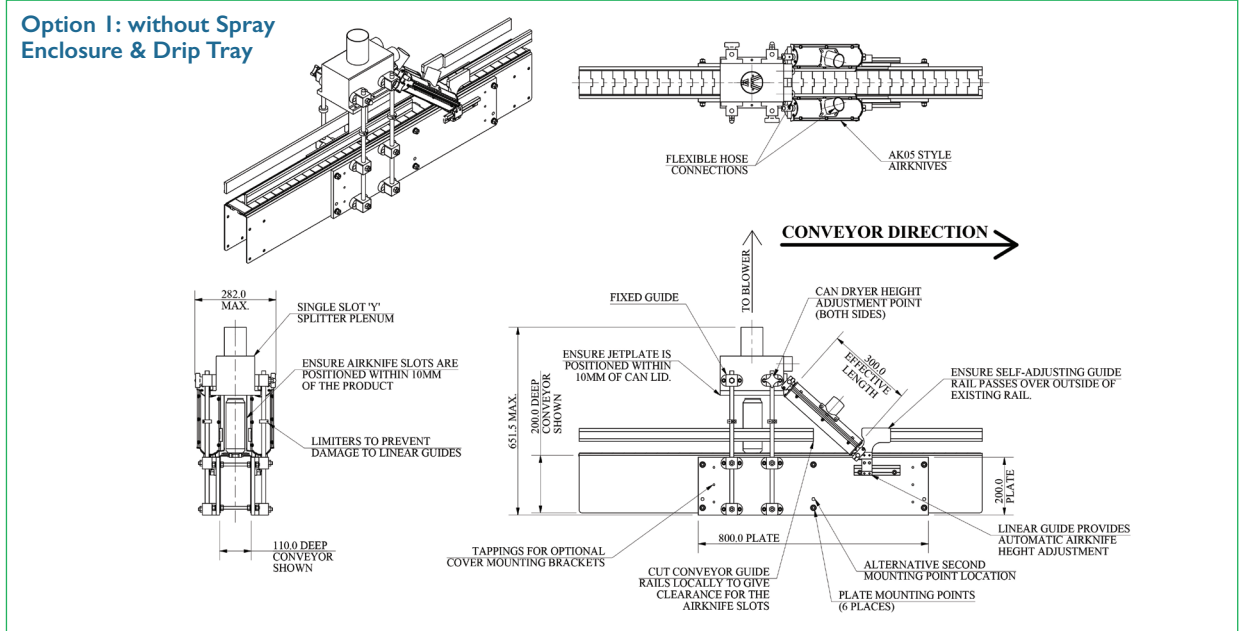

Please note (1) - all drawings measurements are in millimeters (mm)  
Please note (2) - above technical specifications are subject to change

### Comparisons to Compressed Air:

- More cost effective - in operation running costs reduced by as much as 90%.
- Quieter – lower air pressures used reduces the expansion ratio and turbulence of the air produced.
- Cleaner – blower-driven air is both dry and oil free. No expensive additional filtration required.
- Safer – centrifugal blowers operate on the principle of high velocity, low pressure air which presents no danger to operators.

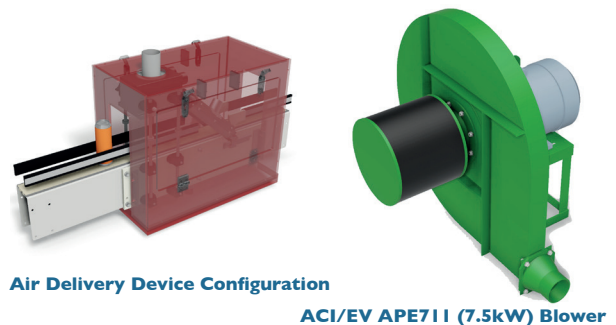

**Air Control Industries Ltd**  
Weycroft Avenue, Millwey Rise Industrial Estate,  
Axminster, Devon, EX13 5HU, United Kingdom  
Tel: +44(0)1297 529242 Fax: +44(0)1297 529241  
Email: sales@aircontrolindustries.com



**Air Control Industries**

## 'Cb-B' - Craft Brewery Bottle Drying System

<b>Configuration</b>	Craft Brewery Bottle Drying System
<b>Product Category</b>	Glass & PET bottles
<b>Application Area</b>	Drying whole bottle prior to labeling

ACI's 'Cb-B' Craft Brewery Bottle Drying System is specifically designed to surface dry glass bottles within craft and micro-brewery operations - whether drying for labeling or packaging. Using a small 7.5kW centrifugal, radial bladed blower, ACI's 'Cb-B' system has been sized for line speeds lower than 10,000 bottles per hour and easily installed, operated and maintained. Noise levels are 92 dB(A) and an optional acoustic enclosure is available for the blower, if required. The system is capable of drying all bottle sizes, providing a minimum water removal efficiency of 96%, and is backed up with a 24 month warranty.

'Cb-B' illustrated:



<b>'CB-B' Items</b>	<b>Quantity</b>
AKSM08 Stainless Steel 304 Modular Air Knives, 600mm long	2
Locline flexible nozzles (12mm diameter)	2
Clamping kits	4
7.5kW Centrifugal Blower (Model APE 711)	1
'Y' Splitter	1
Flexible ducting	2 x 5m
Jubilee clips	6

Drying Systems for Craft & Micro-Breweries  
[www.bottlecandrying.com](http://www.bottlecandrying.com)



**Air Control Industries**

# 'Cb-B' - Craft Brewery Bottle Drying System

'Cb-B' outline drawing  
(Conveyor not included)

www.bottlecandrying.com

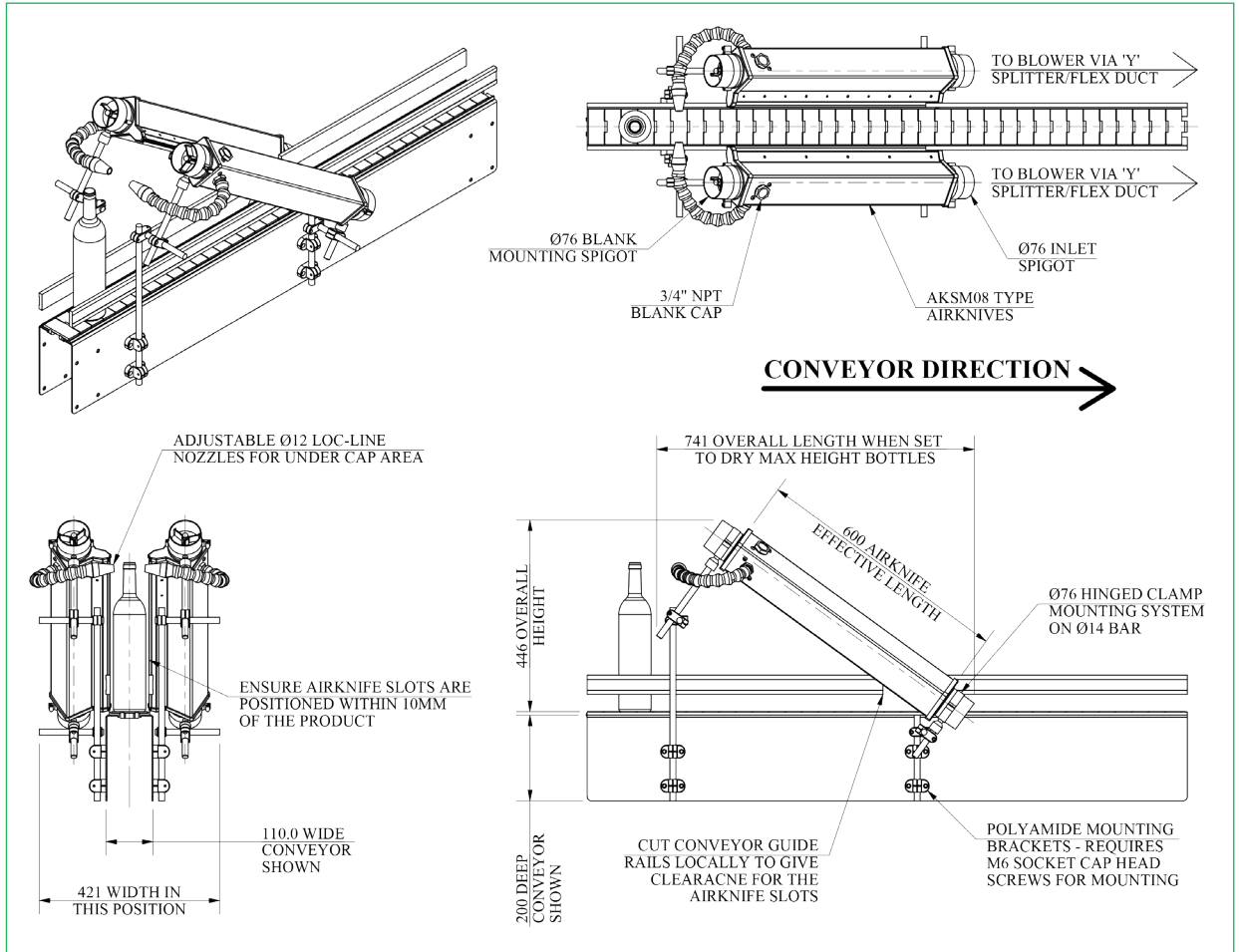

Please note (1) - all drawings measurements are in millimeters (mm)  
Please note (2) - above technical specifications are subject to change

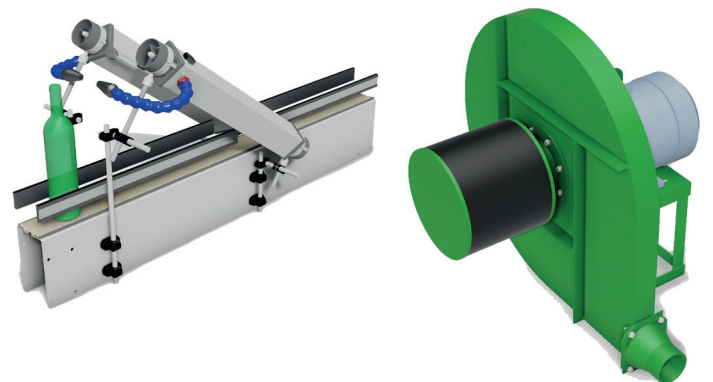

**Air Delivery Device Configuration**

**ACI/EV APE711 (7.5kW) Blower**

## Comparisons to compressed air:

- More cost effective - in operation running costs reduced by as much as 90%.
- Quieter – lower air pressures used reduces the expansion ratio and turbulence of the air produced.
- Cleaner – blower-driven air is both dry and oil free. No expensive additional filtration required.
- Safer – centrifugal blowers operate on the principle of high velocity, low pressure air which presents no danger to operators.

**Air Control Industries Ltd**

Weycroft Avenue, Millwey Rise Industrial Estate,  
Axminster, Devon, EX13 5HU, United Kingdom  
Tel: +44(0)1297 529242 Fax: +44(0)1297 529241  
Email: sales@aircontrolindustries.com



**Air Control Industries**

# 'RM' (Remote Blower) Drying System

<b>Configuration</b>	Remote Blower Drying System
<b>Product Category</b>	All bottles/cans/pouches etc
<b>Application area</b>	Drying specific or complete areas

Without compromising reliability or performance, ACI's 'RM' Remote Blower System is designed to offer a 'bare bones' drying solution that does not compromise drying performance efficiency. This system is ideal particularly for budget restricted and low-volume applications.

**'RM' illustration shown with Air Knives and JetPlates:**

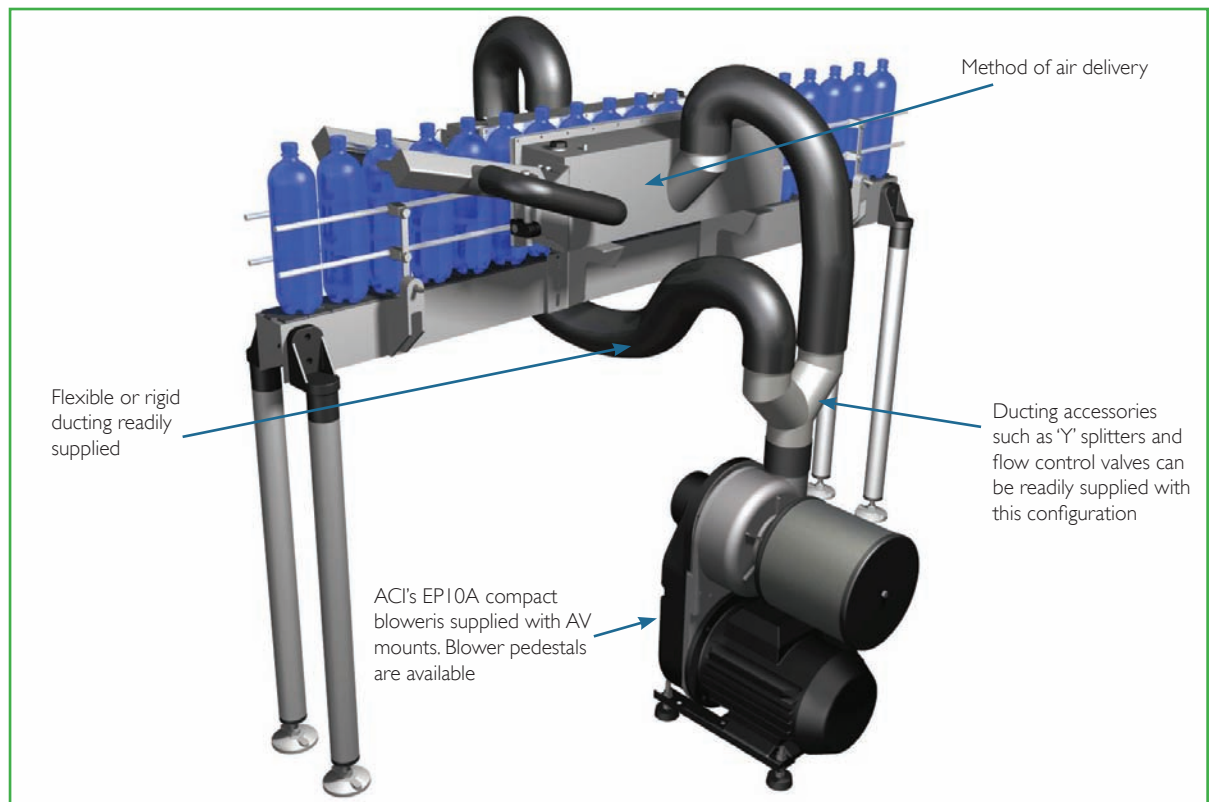

**'RM' system options:**

Option	Blower Specification	Air Delivery Device	ACI Part No
1	15kW EPI10A Blower (18-19,000 rpm)	2 x 1200mm St St Air Knives each fitted with x2 flexible nozzles	RMB-01 15KW
2	15kW EPI10A Blower (18-19,000 rpm)	2 x JetPlates, 2 x 320mm St St Air Knives	RMB-02 15KW
3	15kW EPI10A Blower (18-19,000 rpm)	Can Tunnel (4 slot) with 2 x 500mm St St Air Knives	RMB-03 15KW

**'RM' System shown with Can Drying Tunnel:**



**'RM' System shown with Air Knives:**



**Drying Systems for the Filling Industry**  
[www.bottlecandrying.com](http://www.bottlecandrying.com)



**Air Control Industries**

# 'RM' (Remote Blower) Drying System

The RM system is characterised by having no enclosures supplied for either spray contamination or noise attenuation. The blower must be positioned a minimum of 3 metres (to prevent water ingress into the blower) and a maximum of 10 metres from the drying area (to prevent system performance losses). The blower type recommended for this system will be determined by such factors as the line speed and nature of the application.

## 'RM' outline drawing (illustrated with Air Knives):

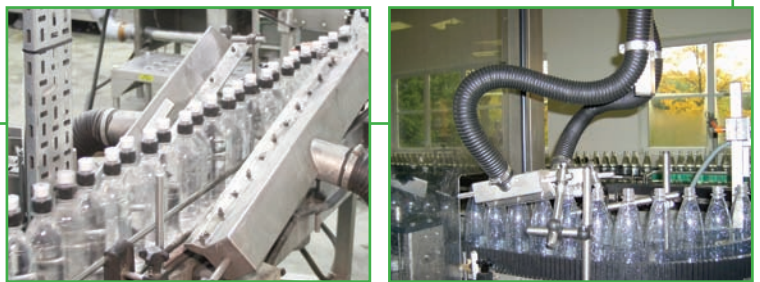
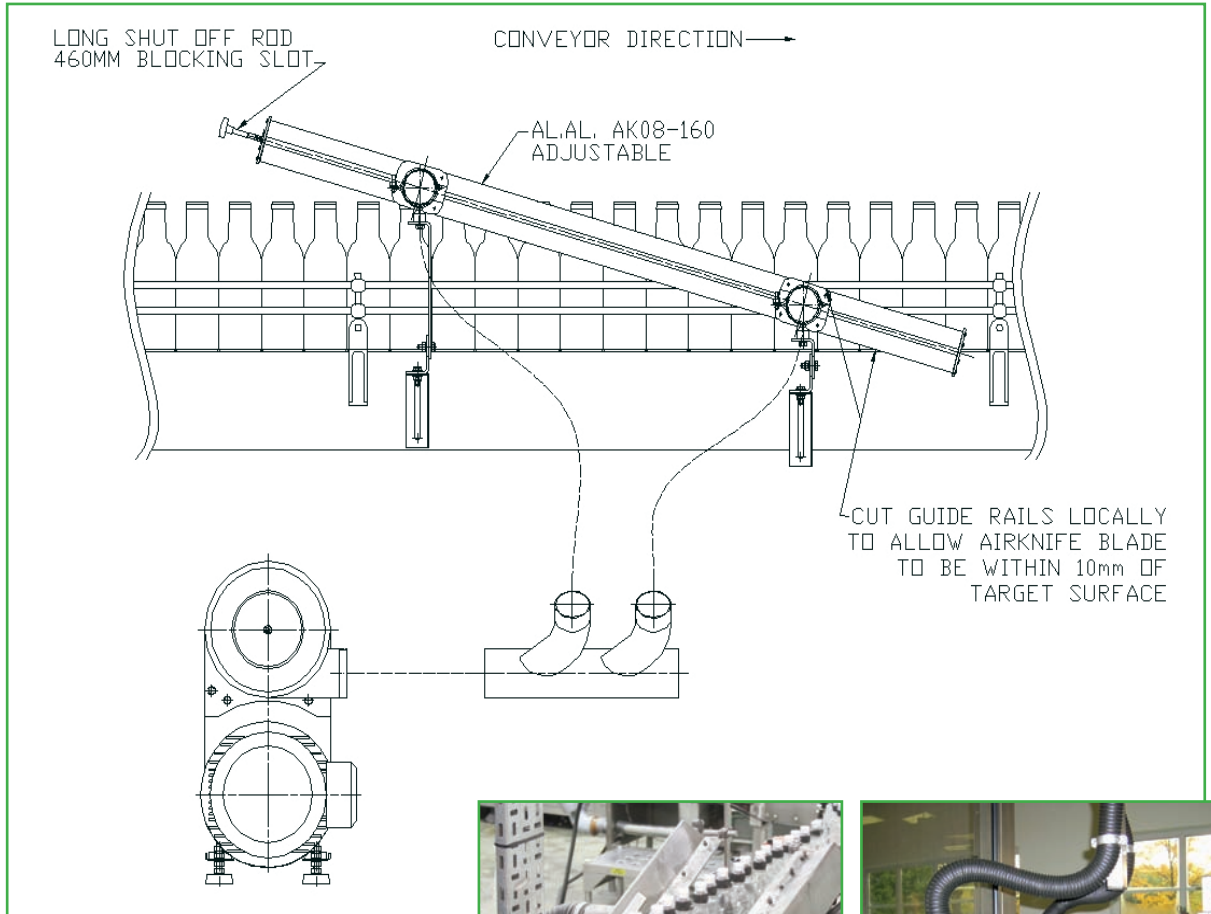

### Other options:

These will include the following:

#### Air delivery devices

ACI can offer a number of alternatives to delivering the air to the product, including Stainless Steel air knives, JetPlates, Can Tunnels, Neck and Cap Dryers.

#### Ducting

In addition to standard flexible hose, both solid stainless or galvanised steel are available.

#### Starters

ACI are able to offer a range of starters for all budgets.

#### Enclosures and pedestals

A number of mounting configurations/blower enclosures are available. Detailed advice can be given to customers on application by ACI's Technical Sales Department.

Ref: DRI-Line DS 2014/V1

**Please note (1)** - all drawings measurements are in millimeters (mm)  
**Please note (2)** - above technical specifications are subject to change

#### Air Control Industries Ltd

Weycroft Avenue, Millwey Rise Industrial Estate,  
Axminster, Devon, EX13 5HU, United Kingdom  
Tel: +44 (0)1297 529 242 Fax: +44 (0)845 5000 502  
Email: sales@aircontrolindustries.com

www.bottlecandrying.com



**Air Control Industries**

# 'EL' (Eye Level) Drying System

**Configuration 'EL'** 'EL' Eye Level Drying System

**Product Category** All bottles/cans/pouches etc

**Application area** Drying specific or complete areas on high speed lines

ACI's 'EL' Eye Level System is a semi-enclosed unit where the supplied blower is contained within a stainless steel enclosure. Additional protection to the blower is given by mounting the enclosure to a leg kit that can be easily positioned either to the side or directly above the conveyor / filling line.

## 'EL' illustrated with Can Drying Tunnel:

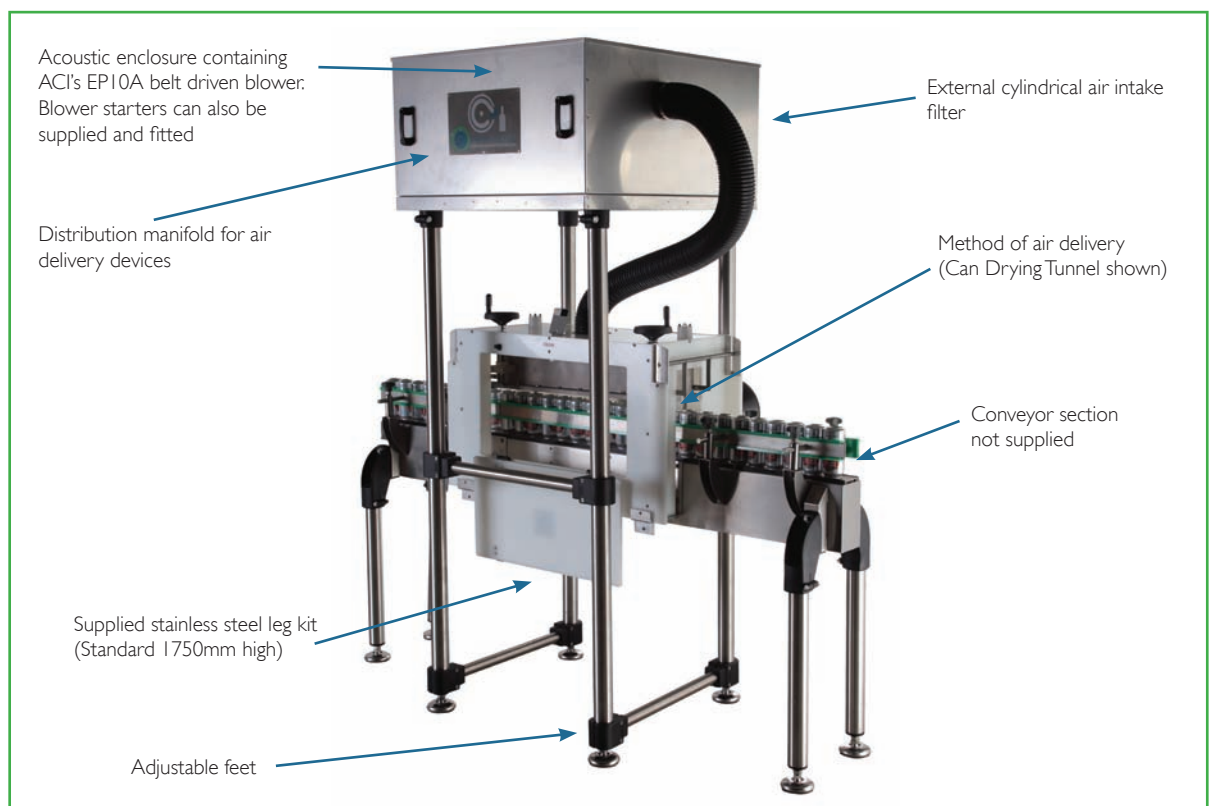

## 'EL' system options:

Option	Blower Specification	Air Delivery Device	ACI Part No
1	15kW EPI10A Blower (18-19,000 rpm)	2 x 1200mm St St Air Knives each fitted with x2 flexible nozzles	EL-01 15KW
2	15kW EPI10A Blower (18-19,000 rpm)	2 x JetPlates, 2 x 320mm St St Air Knives	EL-02 15KW
3	15kW EPI10A Blower (18-19,000 rpm)	Can Tunnel (4 slot) with 2 x 500mm St St Air Knives	EL-03 15KW

Drying Systems for the Filling Industry  
[www.bottlecandrying.com](http://www.bottlecandrying.com)



**Air Control Industries**

# 'EL' (Eye Level) Drying System

ACI's 'EL' Drying System configuration protects the compact blower from any spray contamination emanating from the air delivery device. Noise levels are approximately 90dB(A). Also available in a two-piece stainless steel acoustic enclosure reference 'LC' configuration.

**'EL' outline drawing (shown with Stainless Steel Air Knives):**

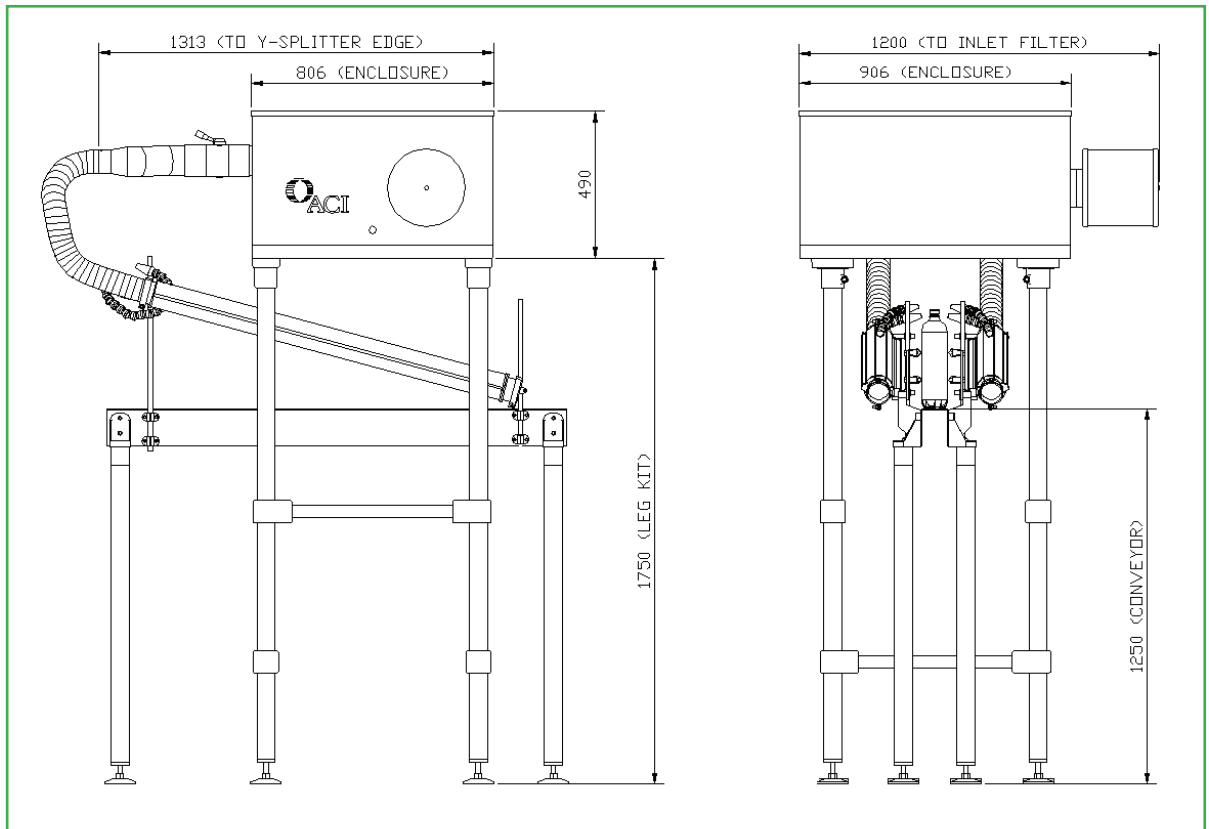

### Other options:

These will include the following:

#### Air delivery devices

ACI can offer a number of alternatives to delivering the air to the product, including Stainless Steel air knives, JetPlates, Can Tunnels, Neck and Cap Dryers.

#### Ducting

In addition to standard flexible hose, both solid stainless or galvanised steel are available.

#### Starters

ACI are able to offer a range of starters for all budgets.

#### Enclosures and pedestals

A number of mounting configurations/blower enclosures are available. Detailed advice can be given to customers on application by ACI's Technical Sales Department.

Ref: DRI-Line DS 2014/V1

**Please note (1)** - all drawings measurements are in millimeters (mm)  
**Please note (2)** - above technical specifications are subject to change

#### Air Control Industries Ltd

Weycroft Avenue, Millwey Rise Industrial Estate,  
Axminster, Devon, EX13 5HU, United Kingdom  
Tel: +44 (0)1297 529 242 Fax: +44 (0)845 5000 502  
Email: sales@aircontrolindustries.com

www.bottlecandrying.com



**Air Control Industries**

# Mini 'LNL' (Low Noise Level) Drying System

**Configuration 'MINI LNL'** MINI Low Noise Level

**Product Category** All bottles/cans/pouches etc

**Application area** Drying specific or complete areas on low to medium speed lines

The 'MINI LNL' system is a compact totally enclosed system where both centrifugal blower and the air delivery device(s) are completely contained within a robust stainless steel enclosure.

### 'LNL' illustration with JetPlates & Air Knives:

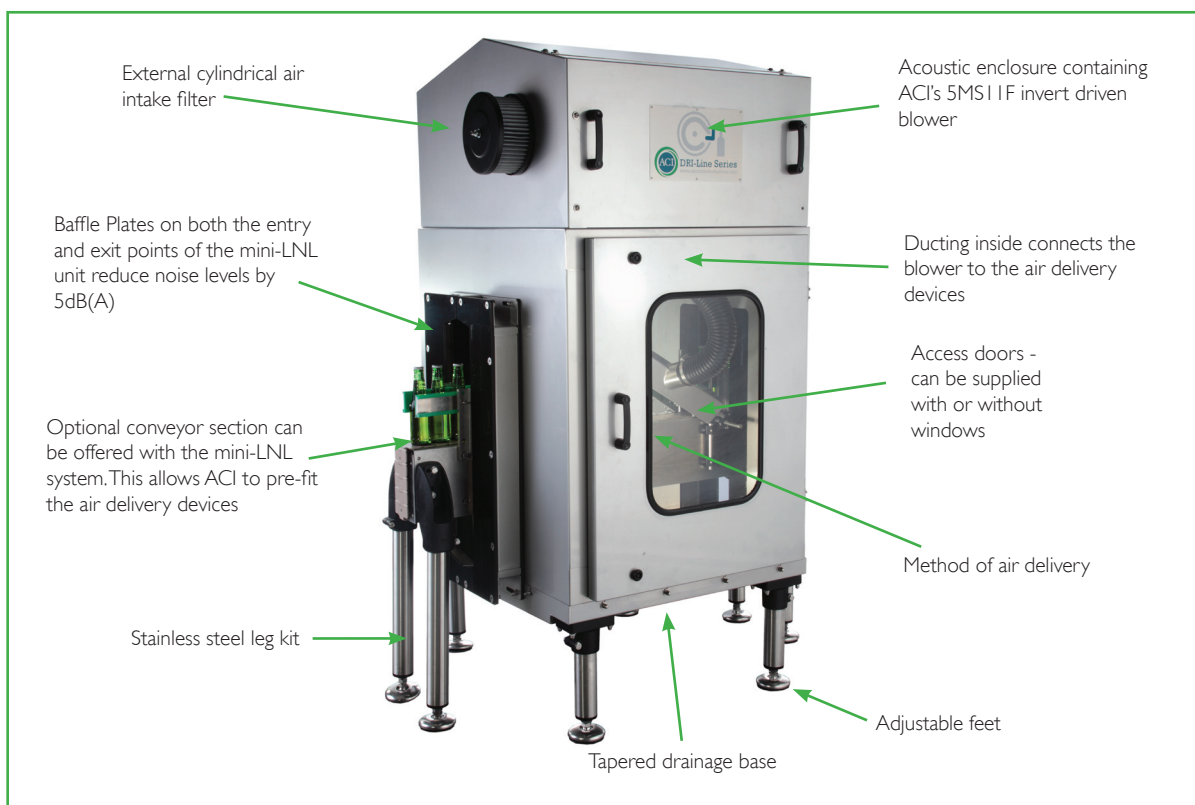

### 'MINI LNL' System options:

Option	Blower Specification	Air Delivery Device	ACI Part No
I	2.2kW 5MS1 IF Blower + Inverter	2 x 400mm St. St. Air Knives	LNL-BESP02I

Drying Systems for the Filling Industry  
[www.bottlecandrying.com](http://www.bottlecandrying.com)



**Air Control Industries**

# Mini 'LNL' (Low Noise Level) Drying System

ACI's 'MINI LNL' drying system is a fully enclosed unit as both the 5MSI I Blower and the Airknives are housed within a sealed, robust acoustic enclosure. This not only protects the blower unit from water/spray contamination, but also attenuates noise levels below 80dB(A). Noise reduction (baffle tunnels) can also be added to exit and entry points of the enclosure to further reducing noise levels.

## 'MINI LNL' outline drawing:

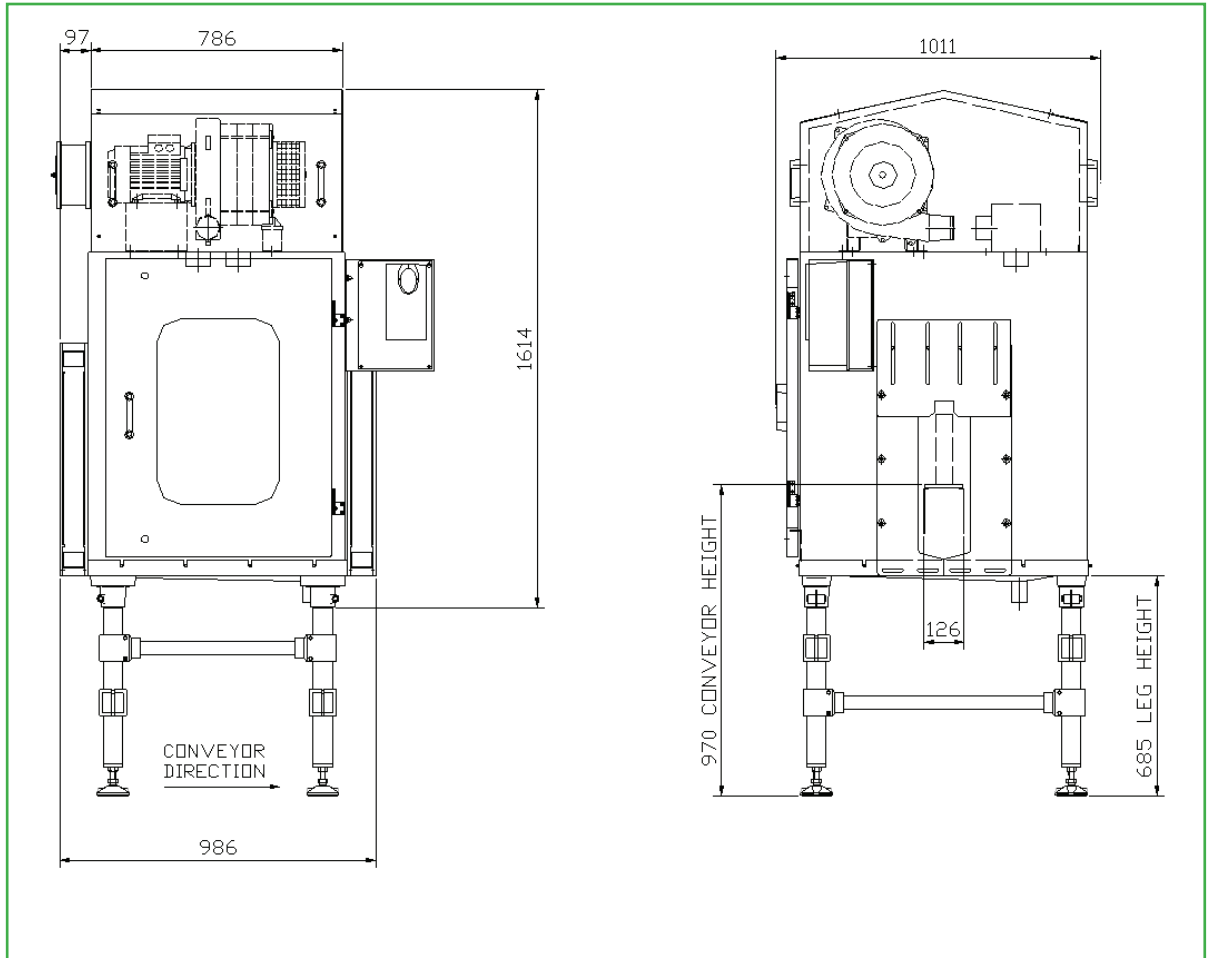

### Other options:

These will include:

#### Air delivery devices

ACI can offer a number of alternatives to delivering the air to the product, including Stainless Steel air knives, Can Tunnels, Neck and Cap Dryers.

#### Starters

ACI are able to offer a range of starters for all budgets.

### Enclosures and pedestals

A number of mounting configurations/blower enclosures are available. Detailed advice can be given to customers on application by ACI's Technical Sales Department.

Ref: DRI-Line DS 2014/V1

**Please note (1)** - all drawings measurements are in millimeters (mm)  
**Please note (2)** - above technical specifications are subject to change

### Air Control Industries Ltd

Weycroft Avenue, Millwey Rise Industrial Estate,  
Axminster, Devon, EX13 5HU, United Kingdom  
Tel: +44 (0)1297 529 242 Fax: +44 (0)845 5000 502  
Email: sales@aircontrolindustries.com

www.bottlecandrying.com



**Air Control Industries**

## 'LNL' (Low Noise Level) Drying System

<b>Configuration</b>	Low Noise Level Drying System
<b>Product Category</b>	All bottles / cans / pouches
<b>Application Area</b>	Drying specific or complete areas on high speed lines

ACI's 'LNL' DRI-Line unit is a premium blower-driven drying system for processing either bottles or cans. It is a totally enclosed, robust unit and comes with access doors on both sides for easy allround access and cleaning operations.

The supplied blower unit (ACI's EPI0A compact blower) is mounted on top of the dryer enclosure where it is protected from all spray contamination. The stainless steel used throughout the 'LNL' is 304 grade, but 316 can be offered. All of the ACI air delivery options offered, including JetPlates, Air Knives, Can Drying Tunnels, Neck and Cap dryer can be used in conjunction with the 'LNL' enclosure format.

### 'LNL' (shown with JetPlates & Air Knives option)

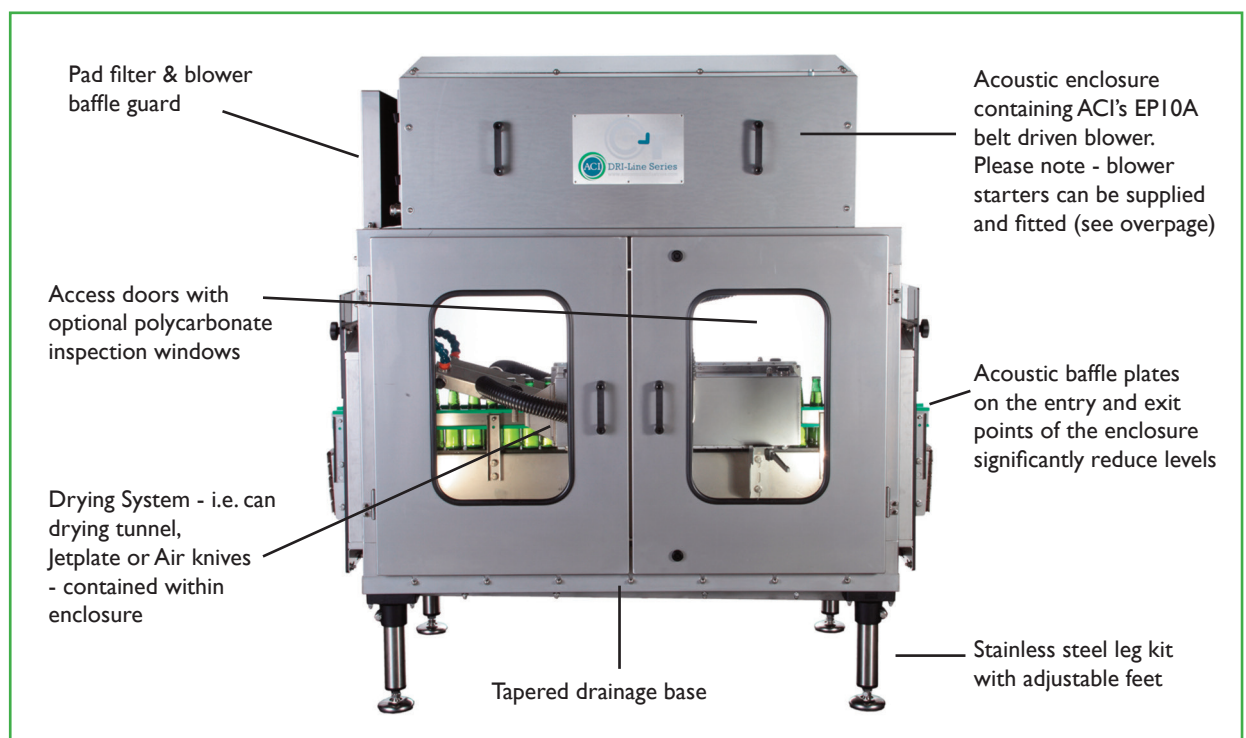

### 'LNL' Enclosure functionality:

The enclosure design performs three important functions:

- Noise attenuation of both the supply blower (ACI's EPI0A compact blower) and air delivery systems
- Protects the blower from any water / spray contamination
- Contains and removes all liquids removed from the product

ACI's standard LNL enclosure comes fitted with one set of noise reducing baffle tunnels (as per the outline drawing on the following page) and reduces noise levels to 83db(A). If an additional set of baffle tunnels is fitted, this will further reduce levels to below 80db(A).



**Air Control Industries**

# 'LNL' (Low Noise Level) Drying System

'LNL' (shown with JetPlates & Air Knives option)

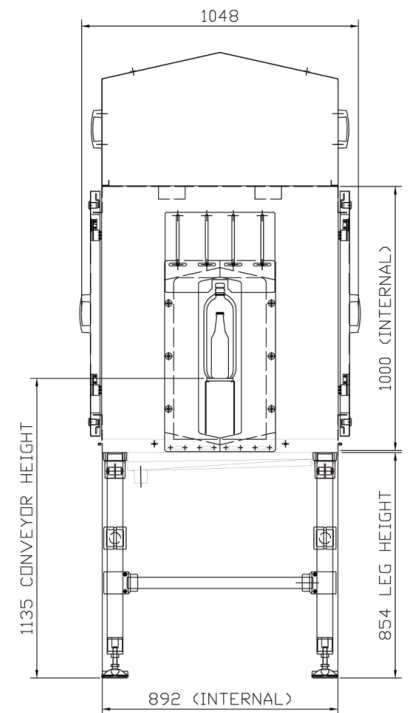
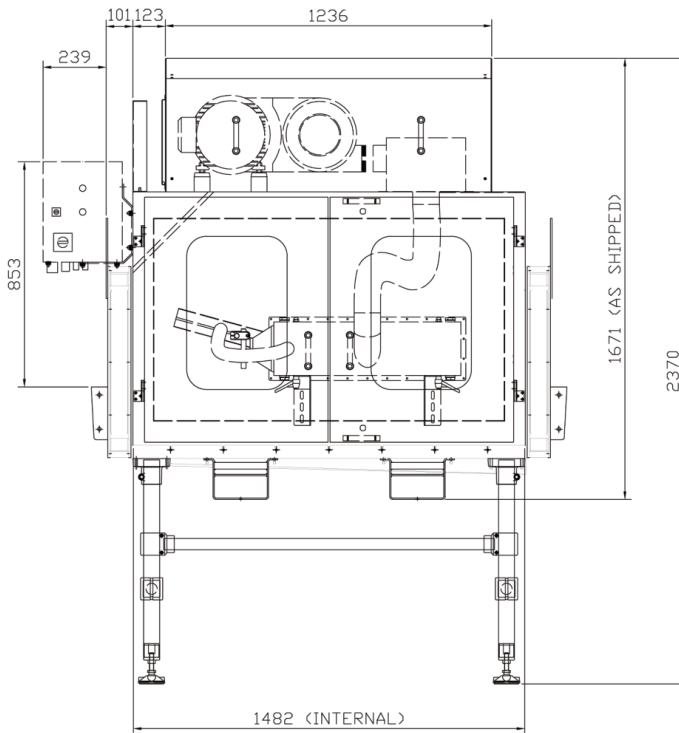

'LNL' Options:

## Starters

The soft start is used as a starting solution & is available through ACI.

Features include:

- Illuminated beacon
- Illuminated run/fault beacon
- Conveyor run or sensor run input
- 24v DC terminals
- Pre-wired to the blower motor
- Lockable door-mounted isolator.
- Housed in an IP65 stainless steel enclosure, with input power cable glands.
- Operate a minimum run time to provide blower start/stop production.

## Enclosures

ACI offer a number of different size options for the 'LNL' configuration, all of which depend on the air delivery devices that have been recommended for your application. All enclosures include adjustable leg kits, and have the additional option of having pre-fitted conveyor plates supplied.

Please note (1) - all drawings measurements are in millimeters (mm)  
Please note (2) - above technical specifications are subject to change

Ref: DRI-Line LNL 2017 V2



www.bottlecandrying.com

**Air Control Industries Ltd**

Weycroft Avenue, Millwey Rise Industrial Estate,  
Axminster, Devon, EX13 5HU, United Kingdom  
Tel: +44(0)1297 529242 Fax: +44(0)1297 529241  
Email: [inquiries@aircontrolindustries.com](mailto:inquiries@aircontrolindustries.com)