

Forge Fan Ultimate

Ref: 5MS8-00054

General Characteristics:



***Image above may not be representative of unit supplied*

Motor type:	Induction type. IPh capacitor start and run
Nominal supply:	240V IPh 50/60Hz
Materials:	Inlets & Fanscrolls - White Polyester Resin Impellers - Aluminium 1200 H14 Stators - White Polyester Resin
Noise levels:	77dB(A) Free Air, 1M

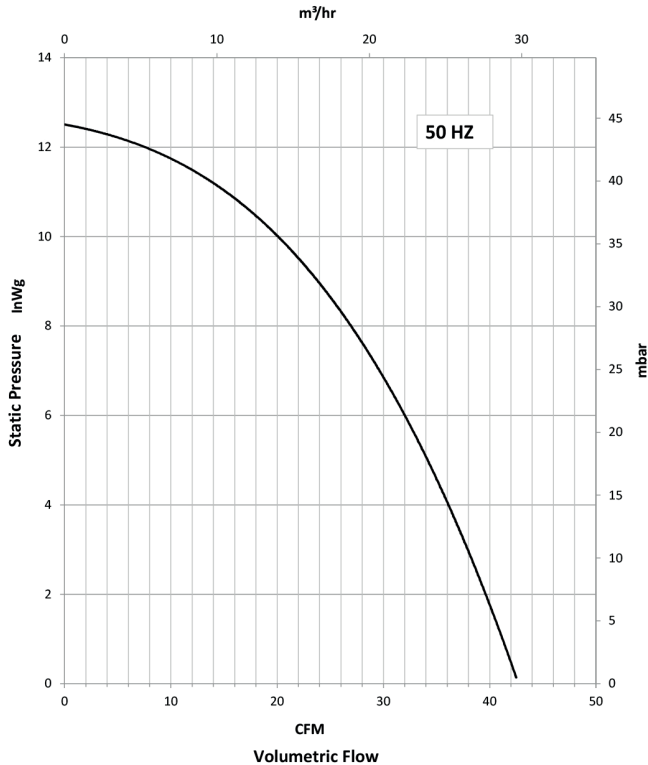

Outline Drawing:

Please note (1) - all drawings measurements are in millimeters (mm)
Please note (2) - below technical specifications are subject to change

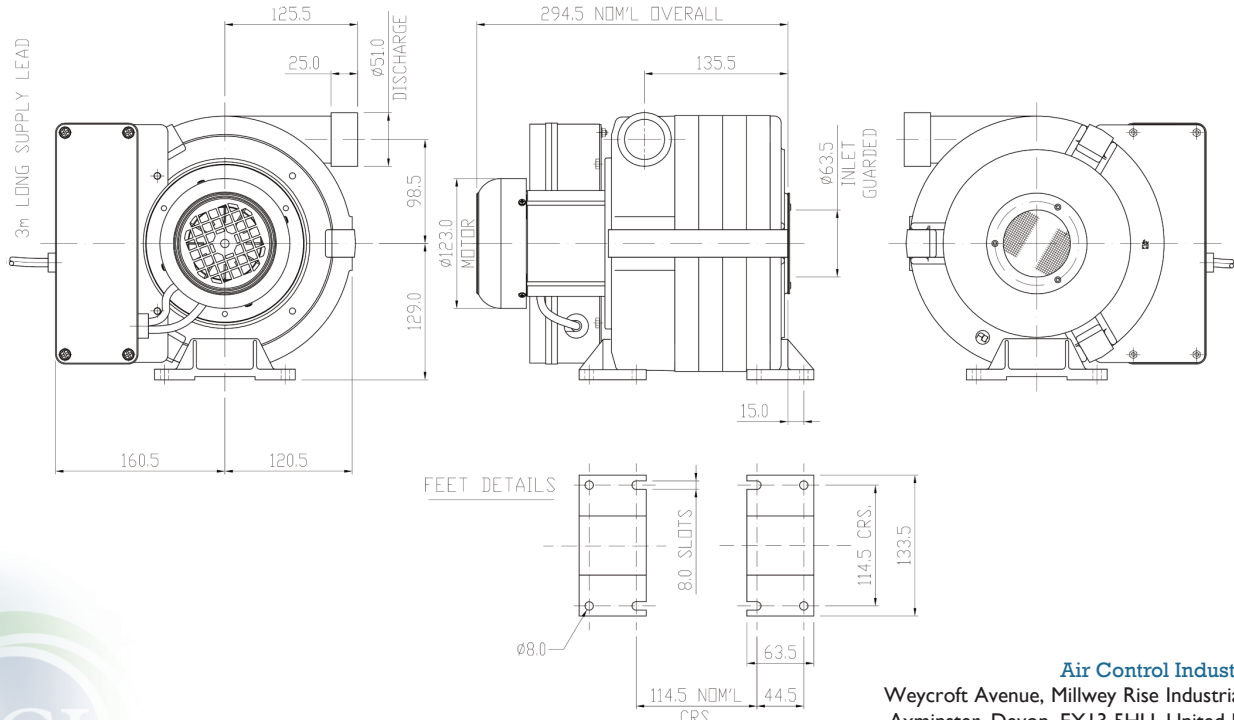

Air Control Industries Ltd
Weycroft Avenue, Millwey Rise Industrial Estate,
Axminster, Devon, EX13 5HU, United Kingdom
Tel: +44(0)1297 529242 Fax: +44(0)1297 529241
Email: sales@aircontrolindustries.com