

Centrifugal Fan VBL8

Single Inlet Centrifugal Fan

General Characteristics:



Motor type:	Squirrel cage induction motor IP55 as std
Nominal supply:	220/240V or 115V 1Ph 50/60Hz 380/420VY / 220/240VD 3Ph 50hz 440/480VY / 250/280VD 3Ph 60Hz
Options:	Inlet & discharge guards, Inlet filters, Spigots
Materials:	Fan case: Cast aluminium LM6 Impellers: Aluminium 1200 H14
Finishes:	Unpainted / Stove enamel (black) as std
Mounting options:	Motor feet or Pedestal
Noise levels:	78dB(A) Free Air, 1M
Weight:	12Kgs / 26Lbs
Motor variations:	ATEX, CE, CSA, UL available

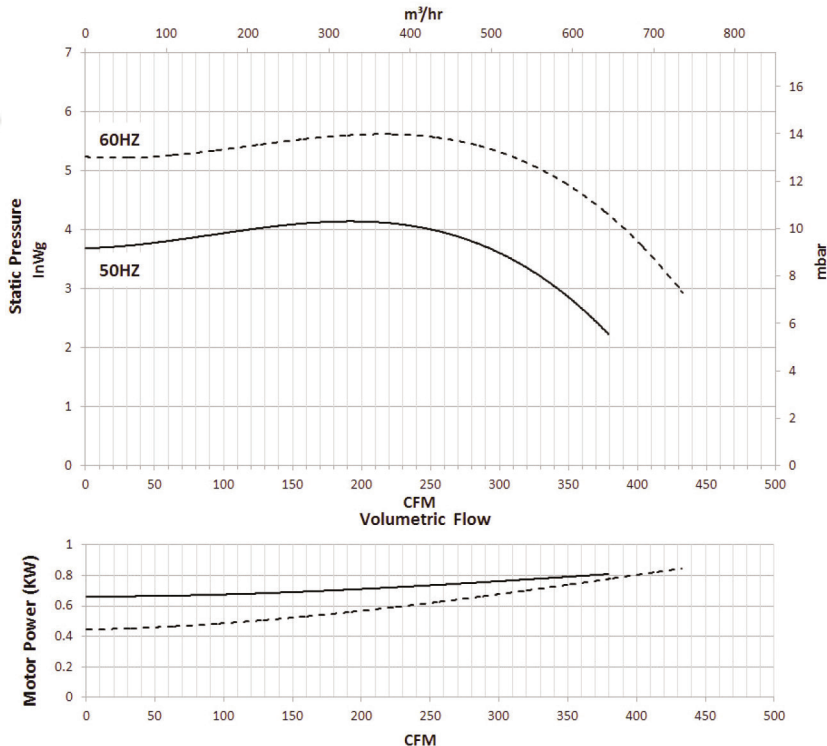

Outline dimensions:

[note: motor shown is for 50Hz performance.
Motor dimensions for 60Hz operation may vary]

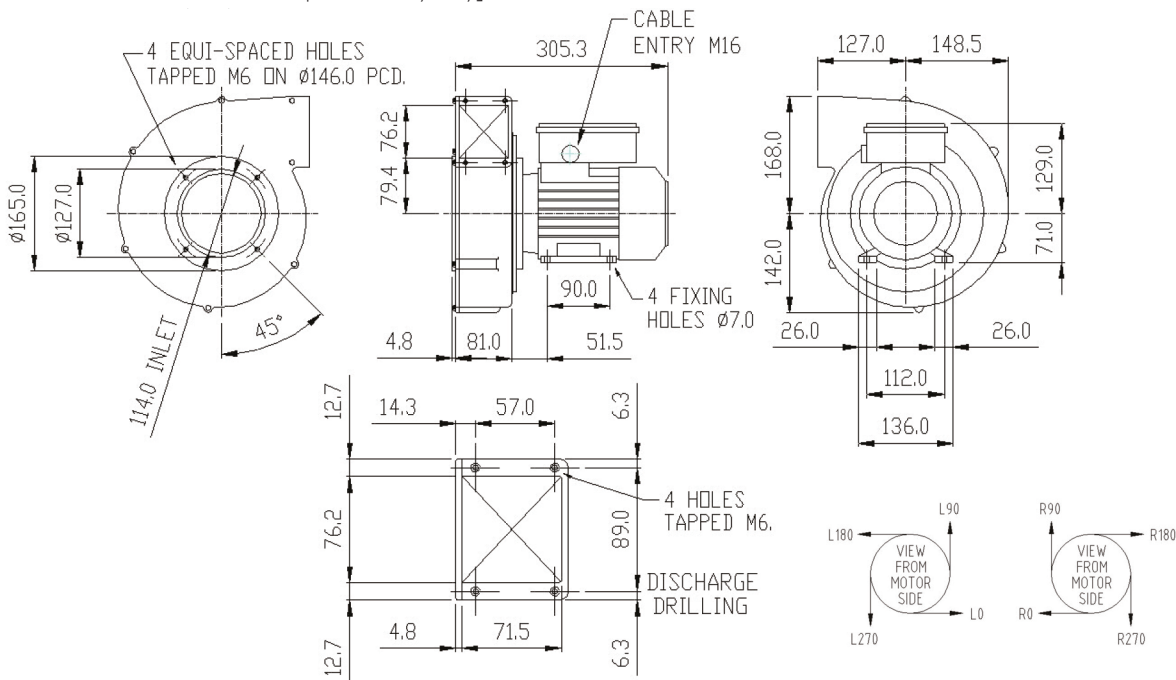

Please note:

- 1 - all drawings measurements are in millimeters (mm)
- 2 - above technical specifications are subject to change
- 3 - Images used may not be representative of the fan supplied

Air Control Industries Ltd
 Weycroft Avenue, Millwey Rise Industrial Estate,
 Axminster, Devon, EX13 5HU, United Kingdom
 Tel: +44(0)1297 529242 Fax: +44(0)1297 529241
 Email: sales@aircontrolindustries.com

www.aircontrolindustries.com