

Centrifugal Fan VBM9

Single Inlet Centrifugal Fan

General Characteristics:



Please note - image above may not be representative of the unit supplied]

Motor type: Squirrel cage induction motor IP55 as std

Nominal supply: 380/420VY / 200/240VD 3Ph 50hz
440/480VY / 250/280VD 3Ph 60Hz

Options: Inlet & discharge guards, Inlet filters, Spigots

Materials: Fancase: Cast aluminium LM6
Impellers: Galvanised sheet steel

Finishes: Unpainted/Stove enamel (black) as std

Mounting options: Motor feet or Pedestal

Noise levels: 80dB(A) Free Air, 1M

Weight: 16Kgs / 35Lbs

Motor variations: ATEX, CE, CSA, UL available

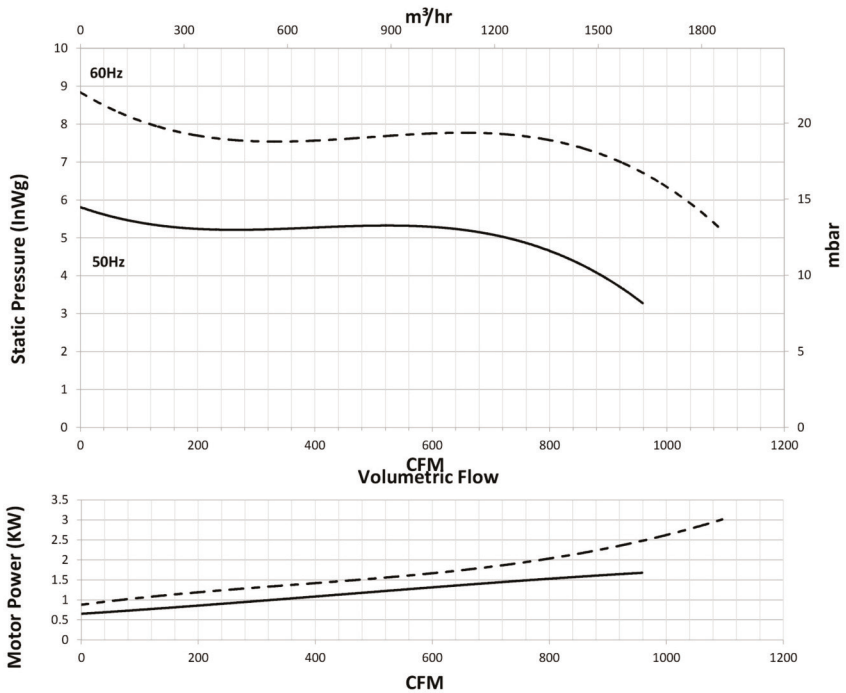

Outline dimensions:

[note: motor shown is for 50Hz performance.
Motor dimensions for 60Hz operation may vary]

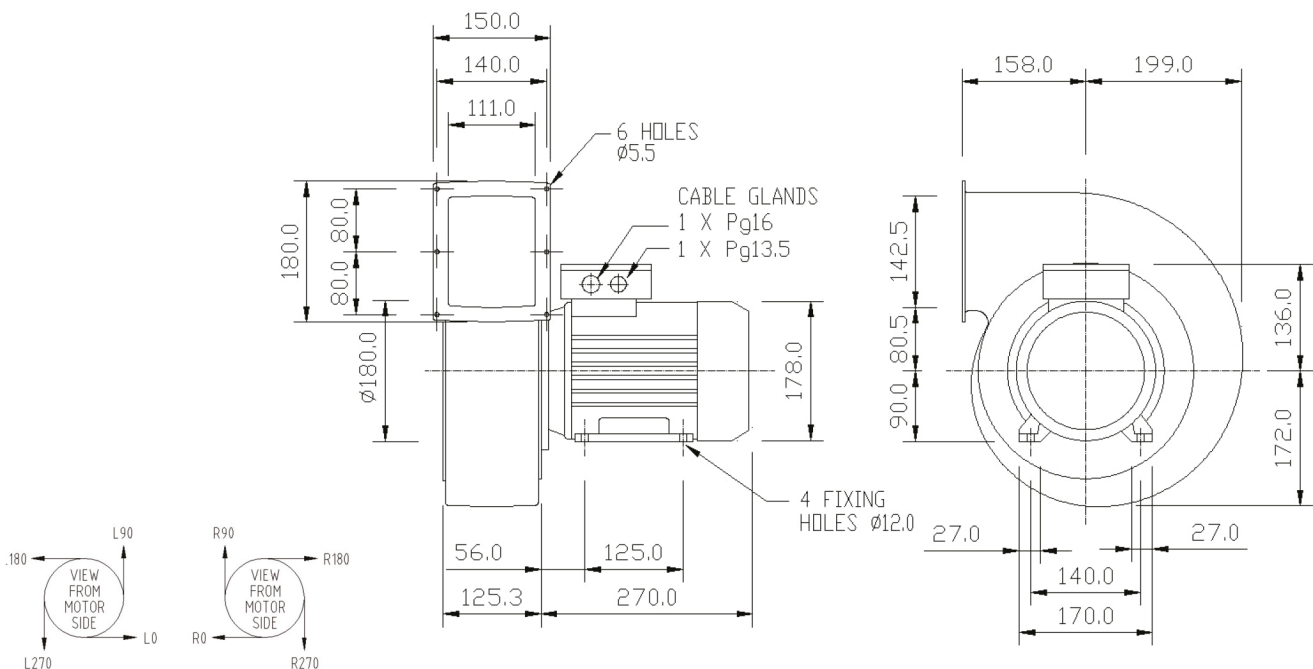

Please note (1) - all drawings measurements are in millimeters (mm)
Please note (2) - above technical specifications are subject to change