

Slimline Fan VBL8/3

Single Inlet Centrifugal Fan

General Characteristics:



[Please note - image above may not be representative of the unit supplied]

Motor type:	External rotor motor / shaded pole induction IP44
Nominal supply:	230V 1Ph 50/60Hz 115V 1Ph 50/60Hz
Ancillaries:	Inlet & discharge guards, spigots, inlet filters
Materials:	Fancase - cast aluminium LM6 Impeller - galvanised sheet steel
Finishes:	Unpainted or stove enamel as std (black)
Mounting options:	Foot, inlet & discharge drillings
Noise levels:	75.6dB(A) Free Air, 1 metre
Weight:	4.8Kg / 10.5Lbs

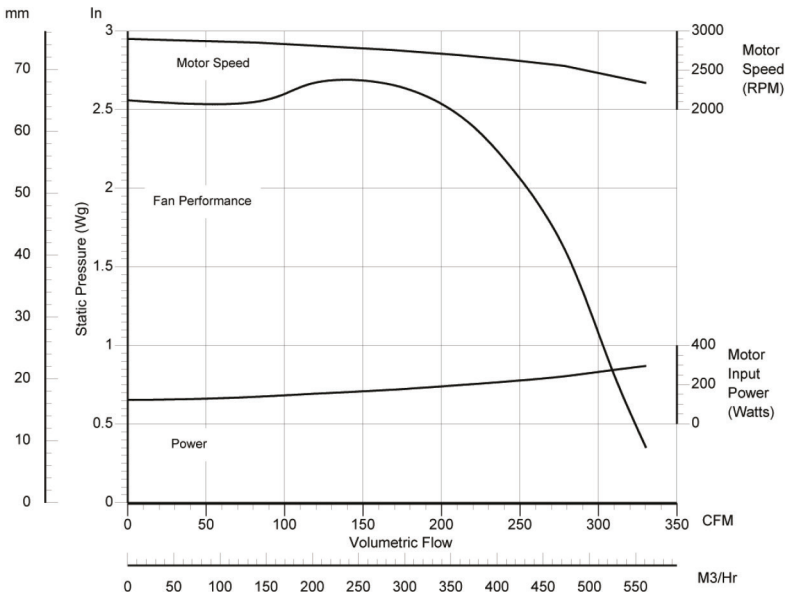

Outline dimensions:

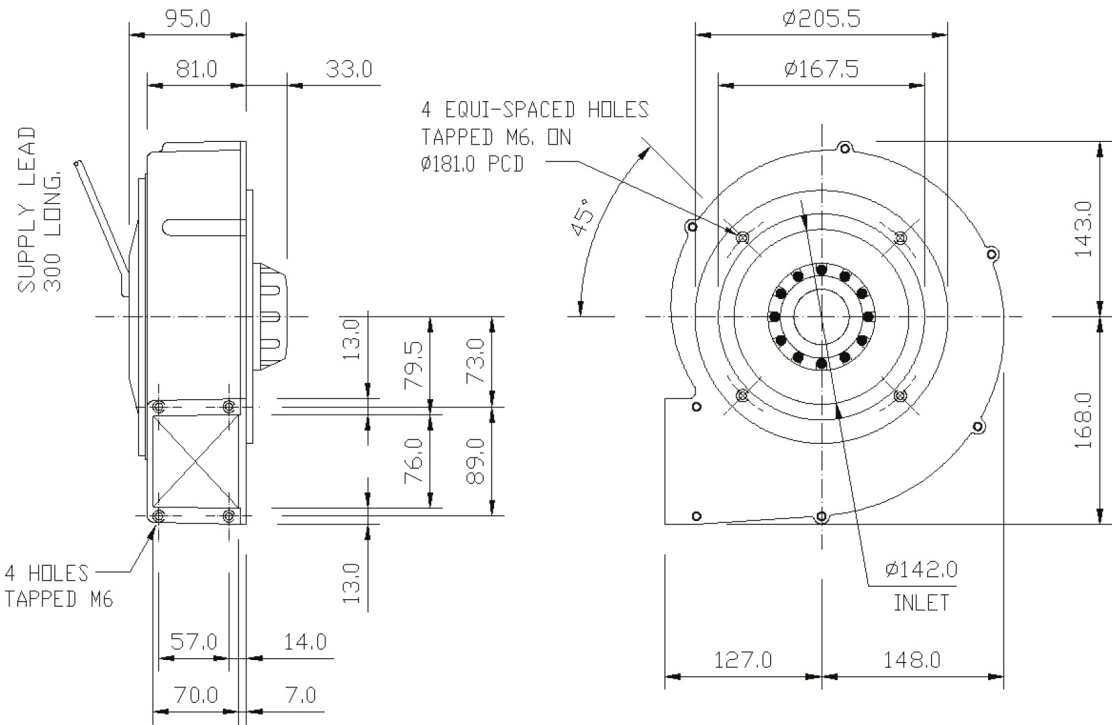

Please note (1) - all drawings measurements are in millimeters (mm)
Please note (2) - above technical specifications are subject to change

Air Control Industries Ltd
Weycroft Avenue, Millwey Rise Industrial Estate,
Axminster, Devon, EX13 5HU, United Kingdom
Tel: +44(0)1297 529242 Fax: +44(0)1297 529241
Email: sales@aircontrolindustries.com

www.aircontrolindustries.com