



Air Control Industries

'EL' Eye Level DRI-Line Series

**Installation, Operation &
Maintenance Instruction
Manual**

Air Control Industries
Ref: EL 2017/Iss1

Table of Contents:

INSTALLATION

- 1. GENERAL INSTRUCTONS**
- 2. GENERAL SAFETY INSTRUCTIONS**
- 3. INSTALLATION**
- 4. TECHNICAL DATA AND EL MATERIALS**

OPERATION & MAINTENANCE

- 5. TIMETABLE FOR KEY MAINTENANCE TASKS**
- 6. GENERAL OPERATIONAL & MAINTENANCE INFORMATION**
- 7. MALFUNCTION-CAUSE-REMEDY**
- 8. CLEANING AND INSPECTION**
- 9. WARRANTY**

1. GENERAL INSTRUCTIONS

- Unpack the containers and check off all of the components against the provided delivery notes.
- Check for damage on arrival. Please check for any transit damage and report it to ACI immediately.
- Follow installation procedures, outlined in this manual.

Image: Main features of the EL System
(Please note – Air knives illustrated)

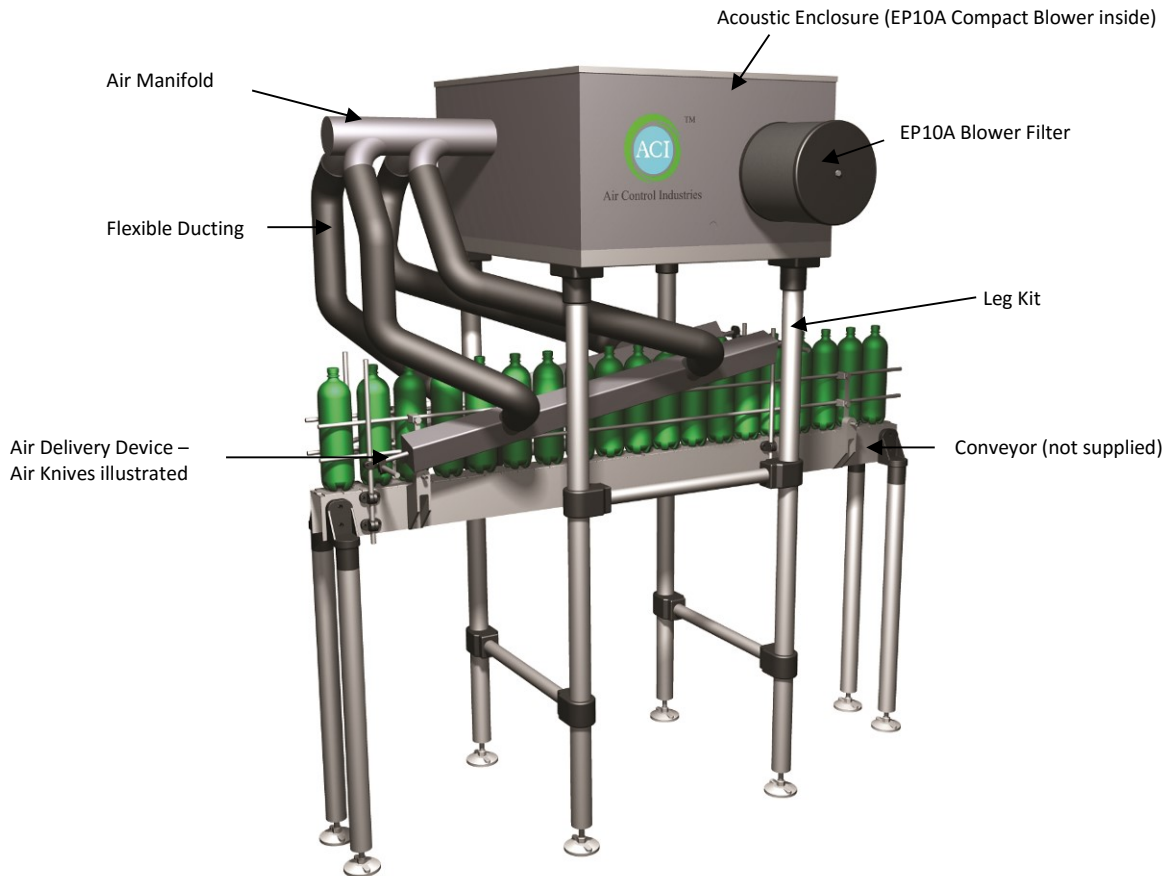
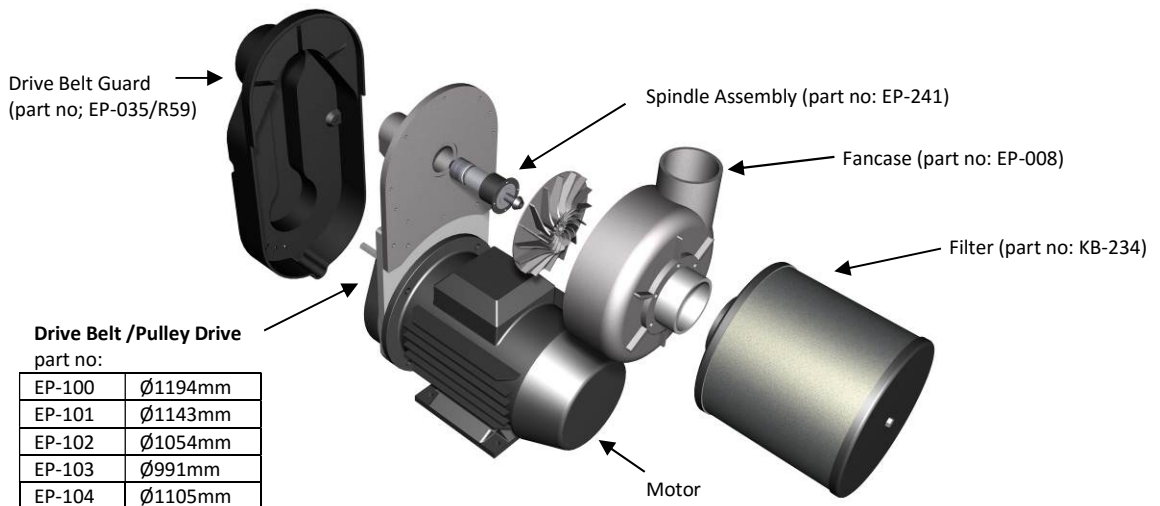

Image: Main features of the EP10A (refer to EP10A manual for full guide)



2. GENERAL SAFETY INSTRUCTIONS



DANGER!

This machinery is for use in heavy industrial current installations. During operation this unit has high speed rotating parts. For this reason, unauthorised removal of the necessary covers, improper use, incorrect operations or insufficient maintenance could lead to severe personal injury or damage of the unit.

Those responsible for the safety of the installation must ensure that:

- Only qualified personnel are entrusted to work on the unit.
- These persons always have at their disposal the operating instructions and other product documentation supplied when they do such work, and that they undertake to follow consistently any such instructions.
- Non-qualified personnel are not permitted to work on the unit.

Qualified personnel are persons who, have had training, experience and knowledge of relevant standards, specifications, accident prevention regulations and operating conditions, have been authorised by those responsible for the safety of the plant to carry out the necessary work and who can recognise and avoid possible dangers. IEE and other relevant regulations should also be observed.

It is assumed that the basic planning work for the installation and all work concerning transport, assembly, commissioning, maintenance and repair is done by qualified personnel or checked by responsible skilled personnel. Note should be taken of the following:

- Technical data and information on permissible use (assembly and connection summaries, operating conditions etc) which are contained in the operating/instructions and motor rating plates.
- General erection and safety regulations.
- The proper use of tools, lifting equipment and safety regulations.
- The use of personal protective equipment.

These instructions cannot claim to cover all details of possible equipment variations, nor can they provide for every possible example of installation, operation or maintenance.

The specified maintenance and inspection measures must be carried out regularly by trained service personnel in order to avoid any interruptions or breakdowns. Deviations from 'normal' performance (i.e. higher temperatures or vibrations) indicate that there is likely to be a malfunction of the unit.

In order to avoid faults the responsible maintenance personnel must be notified immediately.



Danger
electric
shock risk

Danger by electric shock.

If the connecting cable to the blower is damaged, there is a risk of death due to an electric shock. Such defects must be eliminated immediately.

3. INSTALLATION.

- **Installation site demands.**

Upon delivery of the unit to its place of installation, all safety precautions must be followed. Fork lift trucks, elevators or cranes with enough carrying capacity and stability should be used, and the transport and installation should only be carried out by qualified personnel.

Open the crate lid & long side which does not house the leg kit (use a pozi-drive screwdriver). The EL enclosure (shown below) will be on its own internal pallet. Unscrew the EL pallet (from the crate) & remove to a convenient location. Unpack the leg kit & all other items.

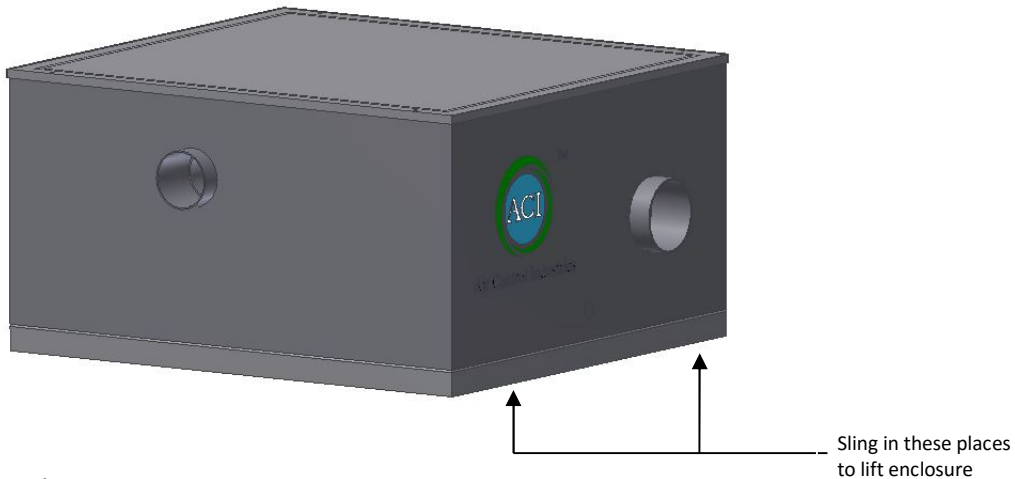

- **Mounting**

- Erect leg kit into the chosen position under the existing conveyor line.
- Connect and secure all ducting.
- Connect Blower. Refer to Electrical Connections overleaf.



Ground Fastenings

In order for the system to be securely positioned the leg kit and the top enclosure will need to be attached and secured together.

- Erect leg kit into the chosen position under the existing conveyor line.
- Position top enclosure onto leg kit. – secure each 4 corner positions by tightening bolt with a 17mm spanner.

Once the leg kit has been secured, the EL Drying unit is completely free standing. However, ACI recommend additional support at the fixing points.

Demands of the installation site.

If no other special equipment is supplied, the following requirements should apply to the installation site.

- The unit is designed for use inside closed production rooms protected against any weather conditions. The unit is not designed for use outside.
- Installation requires an industrial type or concrete floor.

Feet can be fixed to the floor

- **Electrical Connections**

- ACI recommend that a soft start with integrated thermistor control is used to start the blower. A second option is an inverter drive can be used with a ramp up of 6 seconds or over. Finally a star/delta starter can be used, but this is not preferred.
- Customers should always check the motor direction of rotation upon installation.
- All wiring should be installed to national wiring standards.

- **Test Run - Direction of rotation (EP10A blower motor)**

EP10A Electric Motor Terminal Box



Incorrect fan rotation is the most common cause of unit under-performance so great care must be taken here. The direction of the motor cooling fan should be as per the arrow fitted to the motor cowl.

If the motor is running in the incorrect direction, it can be reversed by exchanging two phase leads.



When connecting the blower, ensure that the motor rotates in the correct direction (non drive end / motor cooling fan end). This is the main reason for systems underperforming!!

- **Control**

- ACI's EL units are designed to run continuously. Avoid frequent stop starts – ACI recommend no more than 6 (six) start/stop cycles per hour
- If the blower control is linked to other equipment then ensure that this does not have frequent switching on and off, if so then use a timer delay in the control to avoid frequent switching.
- The EP10A blower needs to have airflow passing through it to ensure temperatures are not exceeded. The use of control valves should be limited to ensure that at least 150 CFM passes through the head at all times.
- Avoid using fast acting valves and diverter valves in the ducting. This can cause sudden back pressure changes which may harm the blower

Wiring diagram: Star / Delta Starter (1 of 4)

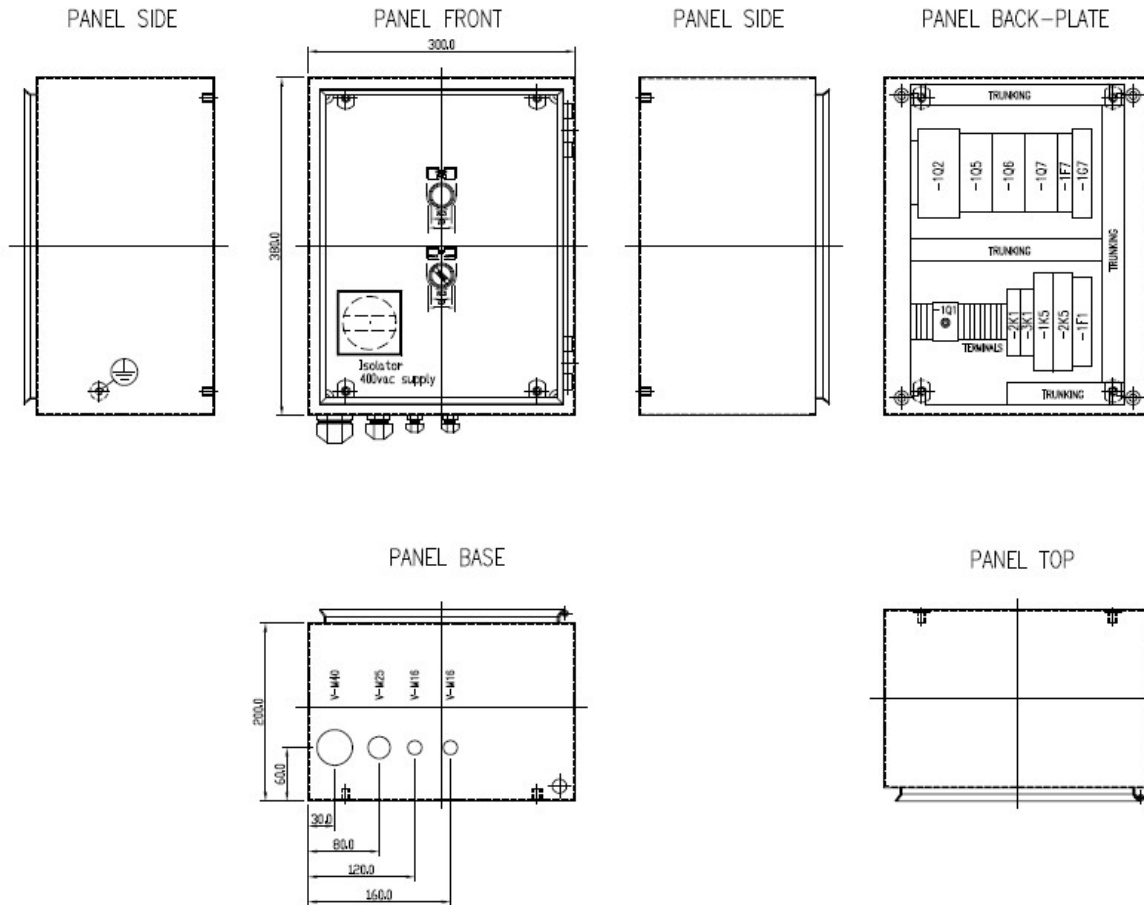

NOTES

1. WIRE COLOURS & SIZES

7.5kW STARTER		
VOLTAGE	COLOUR	SIZE
400/230Vac	BROWN/BLACK/GREY	2.5mm ²
230Vac NEUTRAL	BLUE	1.0mm ²
24Vdc CONTROL	RED	0.5mm ²
VOLT FREE	RED	0.5mm ²
EARTH	GRN/YELLOW	2.5mm ²

11kW STARTER		
VOLTAGE	COLOUR	SIZE
400/230Vac	BROWN/BLACK/GREY	4.0mm ²
230Vac NEUTRAL	BLUE	1.0mm ²
24Vdc CONTROL	RED	0.5mm ²
VOLT FREE	RED	0.5mm ²
EARTH	GRN/YELLOW	4.0mm ²

15kW STARTER		
VOLTAGE	COLOUR	SIZE
400/230Vac	BROWN/BLACK/GREY	4.0mm ²
230Vac NEUTRAL	BLUE	1.0mm ²
24Vdc CONTROL	RED	0.5mm ²
VOLT FREE	RED	0.5mm ²
EARTH	GRN/YELLOW	4.0mm ²

2. ENCLOSURE: IP65
MATERIAL: GRADE 304 STAINLESS STEEL

Wiring diagram: Star / Delta Starter (2 of 4)

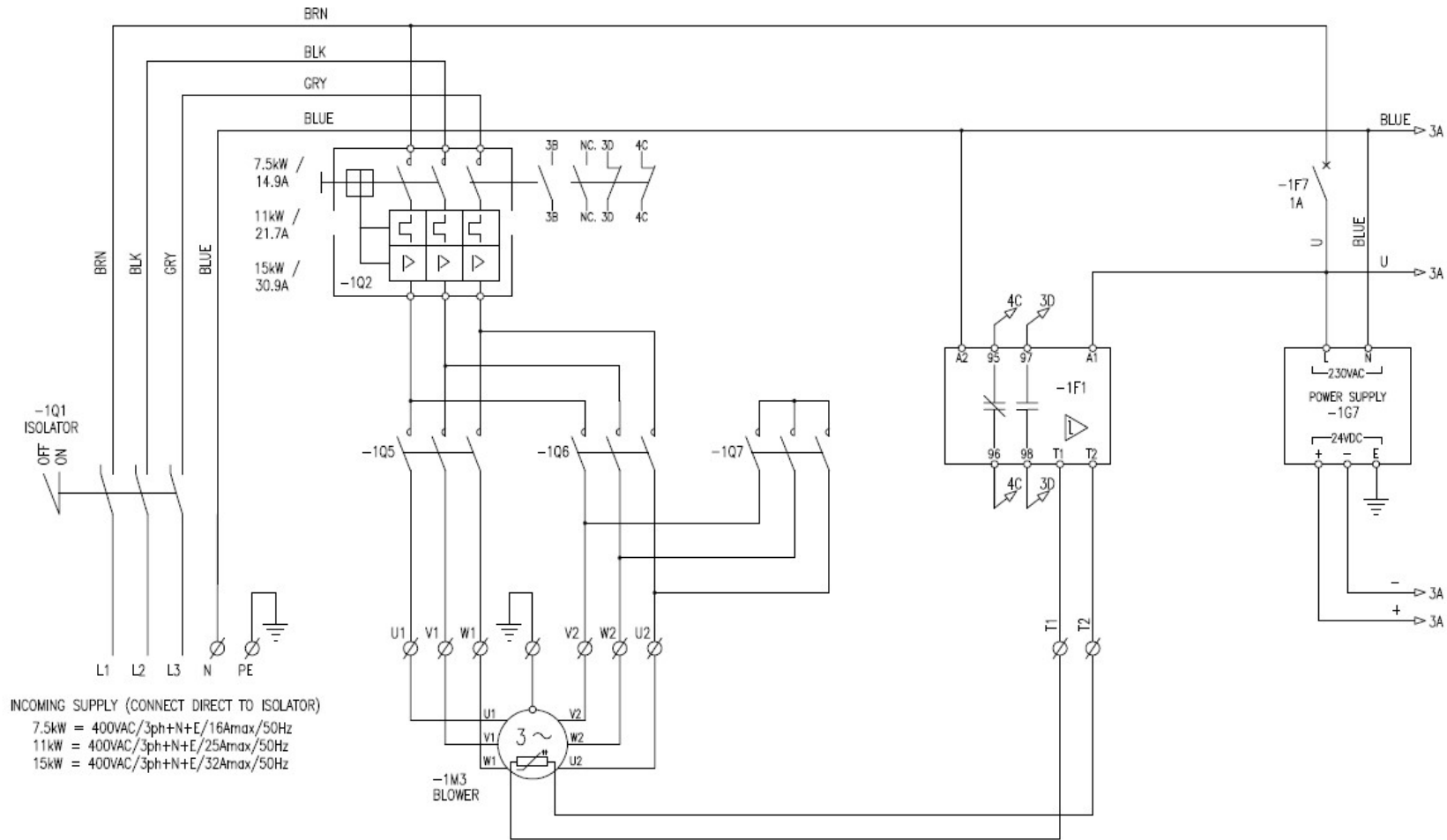

Wiring diagram: Star / Delta Starter (3 of 4)

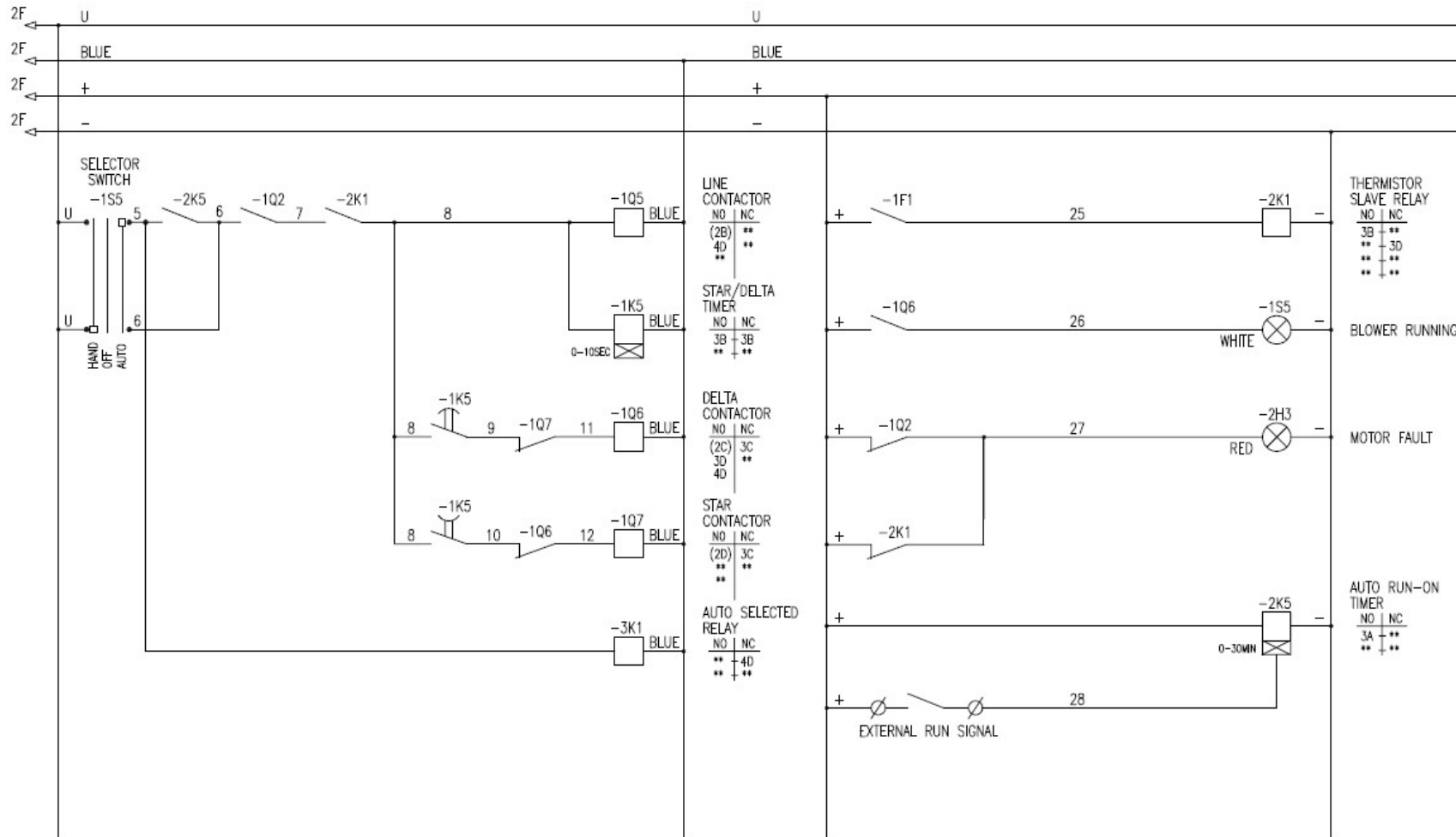

Wiring diagram: Star / Delta Starter (4 of 4)

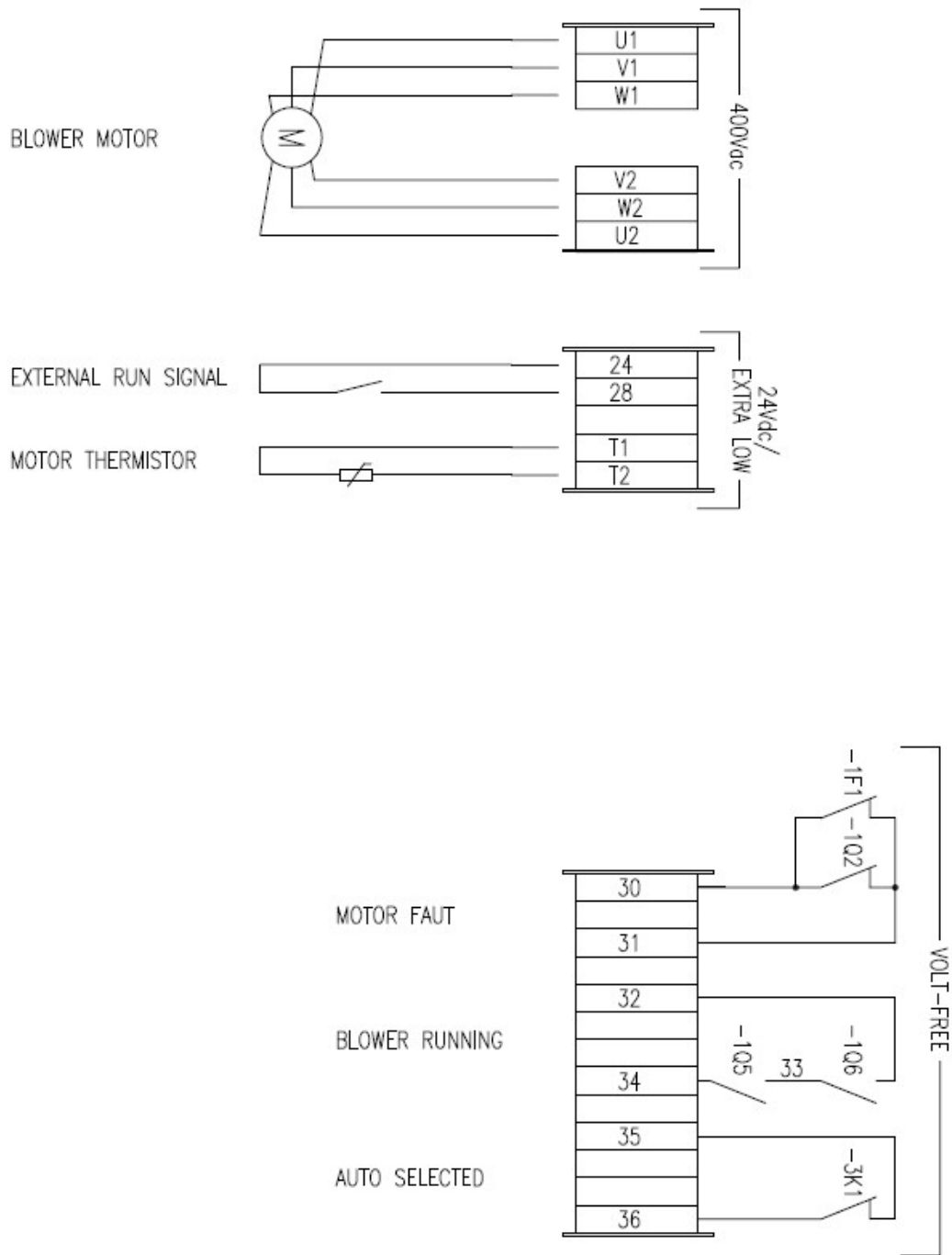

- **ACI JetPlates**

A JetPlate is a large rectangular plenum chamber with a pre-determined slot pattern allowing air to strip liquid off the product. The ratio between the exit slot area and the blower discharge area is sized to give a reasonable back-pressure within the plenum. This ensures an even distribution, giving a uniform exit velocity.

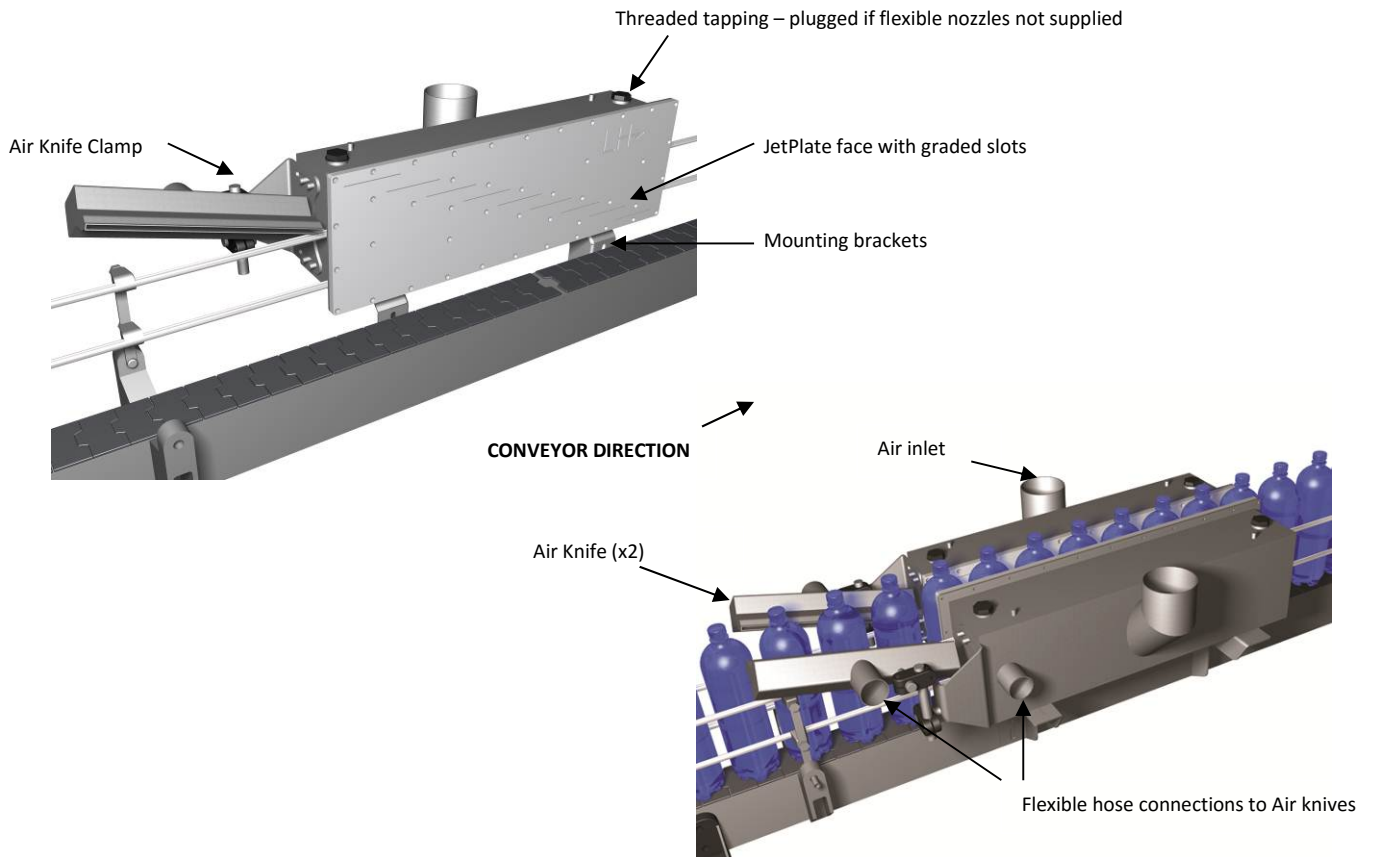

- **Noise Levels**

Please be aware that high velocity air impinging on irregular sharply changing geometry such as a bottle profile, may create unpredictable noise levels.

- **Key Points for JetPlate Mounting**

JetPlates are supplied with a set of mounting brackets which can be directly attached to the conveyor (Please note that the fixings for this item are not supplied).

JetPlates must be mounted so that the slots of the dryer are in line with, and close to, the neck of the bottle being dried. See next page.

Key installation points for mounting JetPlates

1. Any existing conveyor guide rails in front of JetPlates must be removed. The face of the JetPlate will act as the guide rail and if they are not removed drying performance will be severely affected.

Please note - JetPlates must be positioned in the correct direction (i.e. highest slot is the entry point for the bottle's, lowest slot is the exit point for the bottle).



2. An air gap of no less than 25mm and no more than 40mm must be allowed between the bottom of the JetPlate and the conveyor itself.

25-40mm

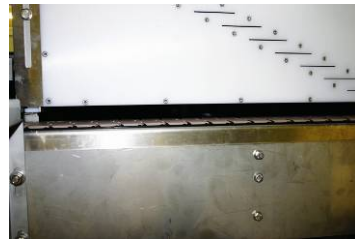

3. All threaded sockets must remain capped if there are no nozzles are required.



4. JetPlates must be positioned within 3mm either side of the bottle being dried. The JetPlates can be easily manoeuvred in and out to accommodate bottles of various diameters.



- **ACI Air Knives**

An Air Knife is a plenum chamber with a smooth convergent path to a controlled exit slot. The ratio between the exit slot area and the blower discharge area is sized to give a reasonable back-pressure along the length of the Air Knife. This ensures an even distribution along the knife giving a uniform exit velocity.

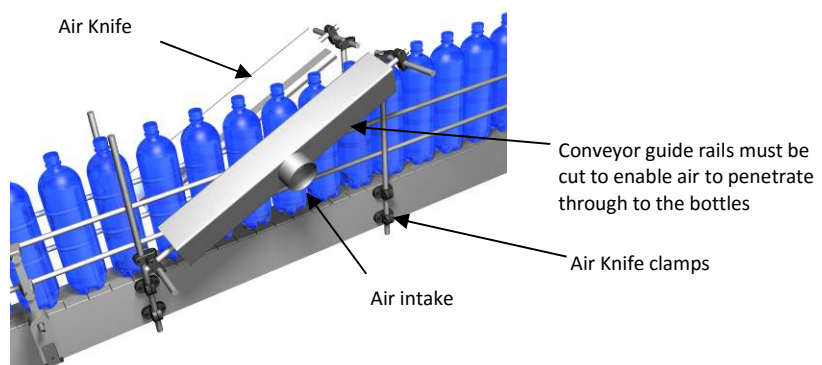

- **Air Knife Noise Levels**

Please be aware that high velocity air impinging on irregular sharply changing geometry such as the bottle profile may create unpredictable noise levels. Opposing Air Knives can also generate high noise levels. By offsetting the Air Knives slightly this problem can be simply avoided. If the noise levels cannot be reduced by changing the attitude of the Air Knife or product then some form of screening may need to be considered.

Key installation points for mounting Air Knives

1. Please ensure that the Air Knives are angled in towards the product (at a 5-10 degree angle) and that Air Knives are not directly opposed. Additionally, ensure Air Knives are as close as possible to the product.



2. Never adjust the Air knife slot – always leave on the original setting.

Please note – if the slot is altered the performance of the whole system will be adversely affected.

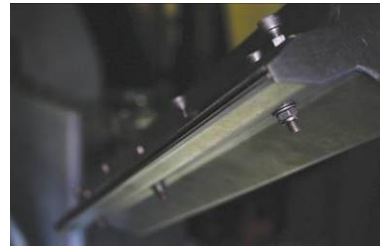

3. All tappings on Air Knives must remain capped if no nozzles are fitted. If tappings are removed, again, performance of the drying system will degenerate.



Please note - The angle of attack of the Air Knife will vary for different products. For example, when drying taller bottles such as a 2 litre PET bottle the angle will be far steeper when compared to a 33cl beer glass bottle. The optimum position will normally be established during trials. Too shallow an angle of attack reduces the impingement effect of the high velocity air onto the product thereby reducing the overall effectiveness.

- **ACI Can Drying Tunnels**

A Can Drying Tunnel is an enclosure that sits over the existing conveyor line. Contained within the enclosure is a plenum with a "Y" shaped exit slot, this parts liquid held in the can recess and pushes it off. The ratio between the exit slot area and the blower discharge area is sized to give a reasonable back-pressure within the plenum. This ensures an even distribution, giving a relatively uniform exit velocity.

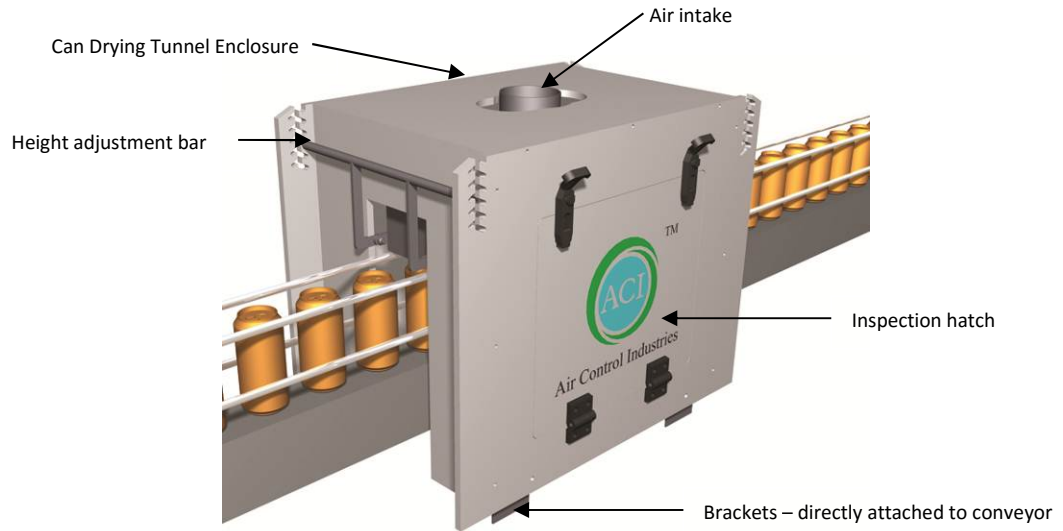

- **Noise Levels**

High velocity air impinging on irregular sharply changing geometry can create high noise levels.

- **Mounting**

The Can Drying Tunnel should be mounted such that at the tunnels lowest height setting, the shortest can is dried effectively (5-10mm above the can). The Can Drying Tunnel will sit directly over the line and allow existing guide rails to stay intact without modification. The Can Drying Tunnel can be raised / lowered to suit various sizes of product by adjustment of the latching handles located at either end, allowing use on multi sized product conveyors.

- **Installation**

Un-pack the containers and check off the components against the delivery notes. See the following diagrammatic instruction for an illustrated installation guide for Can Drying Tunnel Systems.

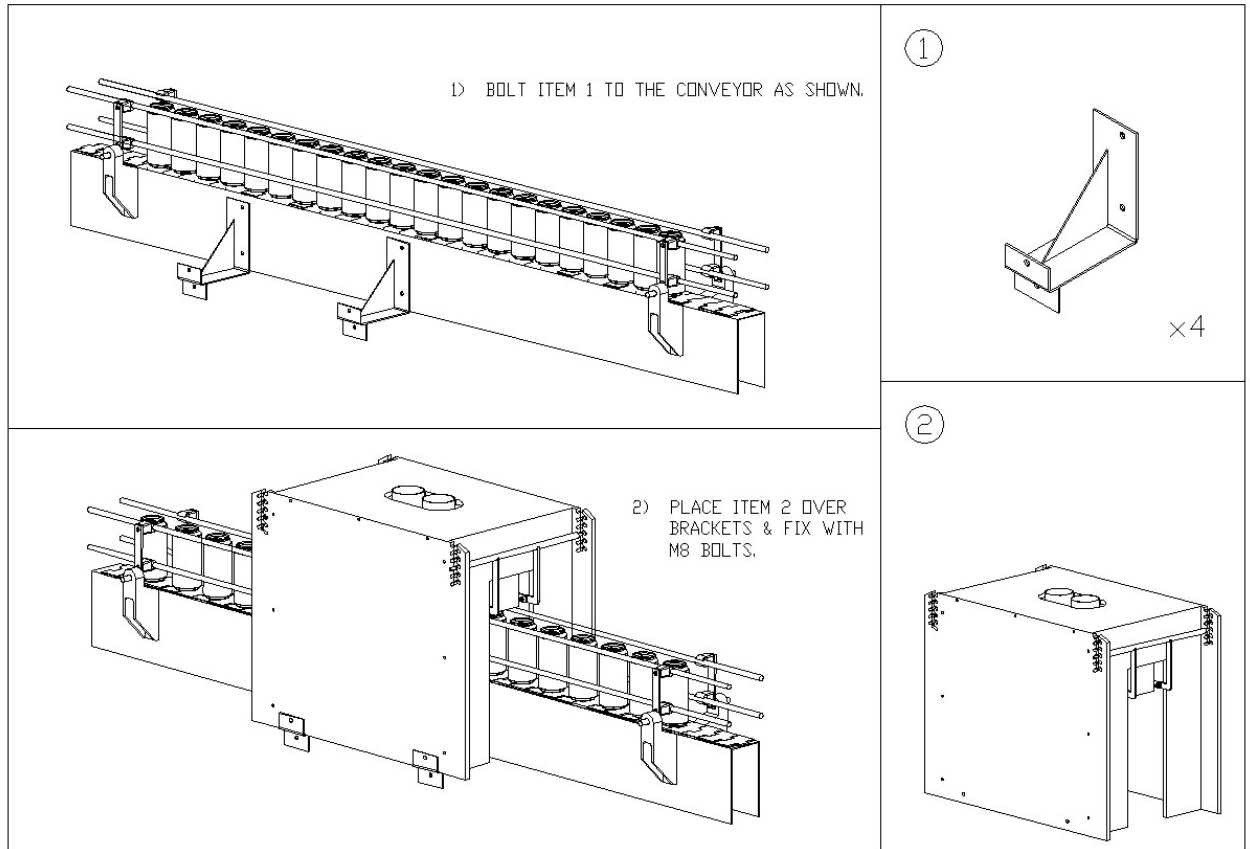

- **Installing Cap Dryers**

ACI's Cap Dryer is a small manifold with a fixed array of nozzles, allowing air to blast liquid off the product (see Fig 5.) If the cap area is required to be dried, a cap drying unit will need to have been supplied.

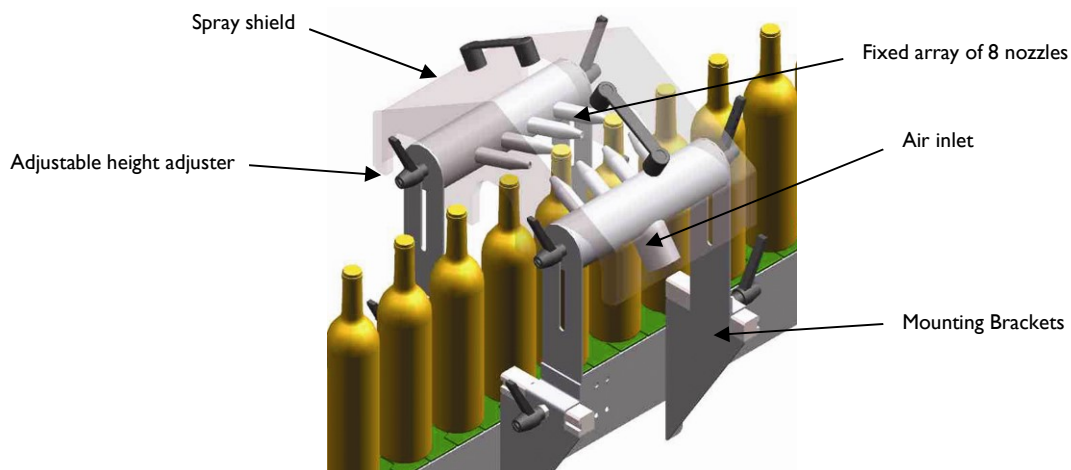

- **Noise Levels:**

Please note that high velocity air impinging on irregular sharply changing geometry may create high noise levels.

- **Mounting:**
 The Cap Dryer is supplied with a set of mounting brackets which can be directly attached to the conveyor (fixings are not supplier). The Cap Dryer should be mounted so that the slots of the dryer are in line with, and close to, the neck of the bottle being dried. The Cap Dryer is designed to fit over the guide bars so no modification of these is required.
 The Cap Dryer can be moved to suit various sizes of product by adjustment of the mounting brackets.
- **Installation:**
 Unpack the containers and check off the components against the delivery notes. For a full diagrammatic instruction for an illustrated installation guide for the Cap Dryer.

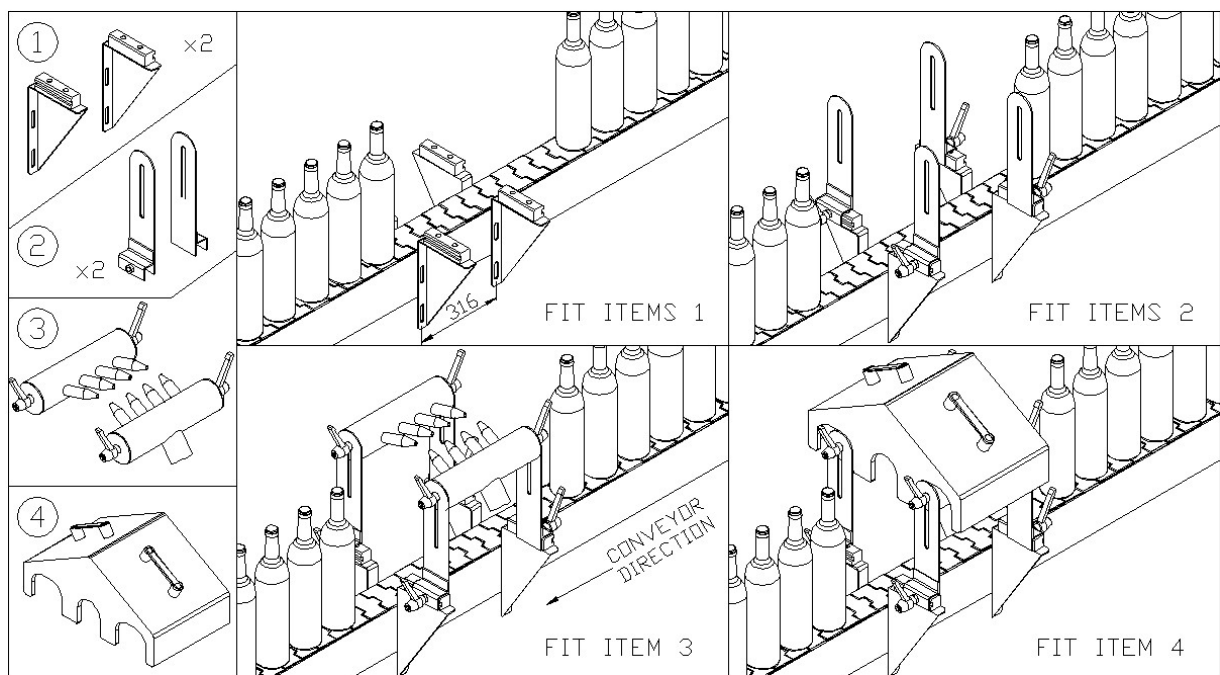

- **Commissioning**
 ACI recommend employing experienced staff for the installation, assembly and start-up of the unit. ACI cannot be held responsible for damage or defects caused by self-directed poor installation, assembly or start-up of the unit.

Installation and commissioning procedures should be carried out by an expert in compliance with local accident prevention regulations.

4. TECHNICAL DATA AND EL MATERIALS

Type: ACI DRI-Line Series – ‘EL’ Eye Level Model

Machine Number: Refer to Serial Number on Motor Label

Year of Manufacture: Refer to Date on Motor Label

Standard voltage: 380/420VY / 660-690Y 3Ph 50Hz
440-480D 3Ph 60Hz

Please note (other voltages are available for this unit)

Motor type: Induction type / TEFC / IP55

Motor power: 7.5/11 or 15kW

Materials:

- All of the stainless steel used throughout the EL DRI-Line Series is 304.
- EP10A Blower materials:
 - Motor – Aluminium
 - Blower head and mounting bracket – Aluminium Alloy LM25
 - Spindle Assembly – Steel EN40B
 - Belt Guard – ABS Plastic
 - Belt – Rubber compound

5. TIMETABLE FOR KEY MAINTENANCE TASKS

Activity Ref.	Frequency	Description	Parts Required	Document Ref.
1	Every Day	Perform general cleaning	None	Section 8.a.
2	Every Week	Basic System Check	None	Section 8.b.
3	Every 3 months	Check the air filters (Top enclosure pad filter, and the EP10A blower cylindrical filter).	KB-234 KN-585/27	EP10A Filter Section 5 of EP10A Compact Blower Manual
4	“	Check Belt Tension	None	Section 5 of EP10A Compact Blower Manual
5	“	Check the integrity of all ducting and fastenings.	None	-
6	“	Check the condition of the blower impeller	None	-
7	“	Check the motor condition and clean if necessary.	None	Section 8.a.
8	“	Inspect JetPlate / Air Knife / Can Tunnel Slots	None	Section 3
9	“	Check for excessive noise and vibration	None	Section 3
10	Every 6 Months	Change Filters	KB-234 KN-585/27	Section 5 of EP10A Compact Blower Manual
11	“	Check Motor	None	-
12	Every 2 years	Change Drive Belts	EP-100 EP-101 EP-102 EP-103 EP-104	Section 5 of EP10A Compact Blower Manual
13	Every 3 years	Change Blower Head	EP-250	Section 5 of EP10A Compact Blower Manual

6. GENERAL OPERATION INFORMATION

a. General safety statement



If any adjustment to the EL unit is required electrically isolate the blower before commencing work.

When operating ACI's EL DRI-Line Drying System, always wear:

- Eye protection
- Ear protection
- Safety footwear

Never:

- Run the blower unit without the belt guard fitted
- Run the blower when disconnected from the JetPlate/Air Knife/Can Tunnel arrangement.

Always ensure:

- The power is isolated and locked off before commencing any maintenance on the system.
- Before operating the system ensure that the EL unit is secured in position.
- Any access covers or guards have not been removed. These items should only be removed if the EP10A compact blower is stationary and isolated from the electrical supply.
- All filters are regularly cleaned and replaced.

b. EL Start up

Apart from the EP10A Blower which is sited in the top enclosure, there are no moving parts in the EL unit. Therefore the EL unit can be started via a plc or a star/delta starter or an inverter depending on which has been fitted. Ensure JetPlates/ Air Knives / Can Tunnel are set correctly

Please note – Generally, it is not ACI or its Distributor's responsibility to ensure control of start/stop. Additionally, if star/delta starting is switched by a plc, it is not ACI's responsibility to ensure timings are correct

c. EL Shut Down

- The EP10A blower should be stopped via a plc, star/delta starter or an inverter.
- The blower is designed to be continuously run and therefore stop/start cycles should be kept to a minimum. 6 (Six) per hour is the maximum level recommended by ACI.
- If linked to the conveyor line, there should be a timer delay fitted to avoid too many stop/starts. If this is not adhered to, damage to the EP10A blower belt and head assembly will occur.

Please note - ACI or its Distributors are generally not responsible for the fitting of any isolators and emergency stops.



Stop/Start cycles must be kept to a minimum – 6 (six) per hour is the maximum amount recommended.

d. Adjustment /Maintenance



If any adjustment to the EL unit is required electrically isolate the blower before commencing work.

i. JetPlates

- Loosen fixing handles and adjust accordingly (see Figure 6).
- Take 3 bottles of size required
- Place one either end and one in middle of JetPlate
- Face of JetPlates should be within 3mm of the sides of bottles (see Figure 7)
- Re-tighten fixing handles

JetPlate Mounting Bracket



JetPlate Positioning

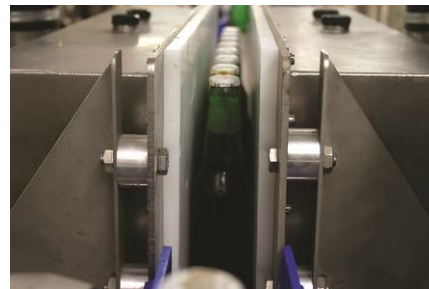

JetPlates require little maintenance. However, some important points are as follows:

- Blocked JetPlate slots can be cleaned as necessary using a non-metallic tool to remove blockages as this can result in damage to the JetPlate. **Please note** - never allow liquid to pass into the plenum and therefore into the blower.
- If threaded blanking plugs have been fitted to JetPlates, never remove them unless replacing with a flexible nozzle.
- There must always be an air gap of 25-40mm between the bottom of the JetPlate and the conveyor.

ii. Air Knives

In order to operate effectively, and efficiently, it is paramount that ACI Air Knives are positioned, and remain positioned correctly. Ignoring this instruction may lead to a noticeable loss of performance.

Correct Air knife Positioning when used in conjunction with JetPlates:



The angle of the Air Knife is completely bottle dependant. For example, when drying taller bottles such as a 2 litre PET bottle the angle will be far steeper when compared to a 33cl beer glass bottle.

Also note, that the Air Knives should be turned in towards the conveyor at an angle of 5-10 degrees.

Air Knives require little maintenance. However, some important points are as follows:

- Blocked Air Knife slots can be cleaned as necessary using a non-metallic tool to remove blockages as this can result in damage to the Air Knife. Please note - never allow liquid to pass into the plenum and therefore into the blower.
- If threaded blanking plugs have been fitted to Air Knives, never remove them unless replacing with a flexible nozzle.

iii. **Can Drying Tunnels**

Can Tunnels require very little maintenance. However, the following points should be noted if the DRI-Line System's performance reduces:-

- Blocked inlet filter on the blower (please refer to the EPI10A Compact Blower Manual, ref: ACF142)
- Blocked Can Drying Tunnel Slots

If either occurs, always switch off the air supply, and isolate the blower. Then:

- Check the Can Tunnel is set to the correct height (i.e. 5 to 10mm above the can). Also check the cans are passing through the tunnel in the right direction.
- Reduced Flow: Dis-connect the hose from the tunnel inlet, remove the mounting screws and remove the tunnel from the conveyor.
- To remove blockages open the front of the plenum by removing the screws around the edge of the slot plate

iv. **Cap Dryer**

These units require little maintenance other than regular cleaning. General inspection of flexible hose and routine cleaning will be required only.

v. **EPI10A Compact Blower**

To carry out any adjustments to the EPI10A blower (i.e. Belts, Filters) please refer to separate EPI10A Compact Blower Manual.

vi. **Ducting and clamping**

All ducting and clamping can be easily adjusted if necessary. All fitted jubilee clips can be adjusted using a standard size flat-headed screwdriver.

e. **Vibration and Noise:**

i. **Enclosure**

Work related emission value is <85dB(A) during idle operation. If noise levels below this are required, specific sound reduction equipment may be supplied at an extra cost. If further information is required please contact ACI directly:

Telephone: **+44(0)845 5000 501**
Email: **sales@aircontrolindustries.com**

i. **EPI10A Blower / Filter Units (Please refer to EPI10A Manual for further details)**

Due to the nature of ACI's drying equipment noise emissions from the EPI10A Blower will always be present during normal working conditions. This is due to the high speed rotational characteristics of the unit (the EPI10A Blower can generate speeds of 20,000 rpm).

If there is either excessive vibration and/or noise from the EPI10A Blower, the following procedures must be followed.

- Electrically isolate the blower.
- Remove top enclosure panels to access the blower (requires ACI key which is supplied).
- Remove the belt guard using 4mm Hexagon key.
- Check the tension on the belt using the supplied Kriket gauge located on the mounting plate.
- Additionally, check the belt for fraying and general wear and tear.
- If the belt is in any way damaged, change it immediately. Do not operate the blower until a new belt is fitted and the belt guard refitted.

If the EPI10A blower is showing a reduced performance:

- Electrically isolate the blower.
- Remove the top enclosure panels so the blower motor and cylindrical filter are visible.
- Remove and replace filter element. See the following section for further information.
- Briefly apply power to the blower to check the rotation of the motor. The direction of the motor cooling fan should be as per the arrow (anti clockwise) viewed non drive end.



Incorrect fan rotation is the most common cause of drying system under performance. Double check!

It is essential that air filters are regularly maintained and replaced.

7. MALFUNCTION-CAUSE-REMEDY

Please Note – any references to ACI’s EPI0A blower, please refer to the EPI0A Manual for further details.

Malfunction	Possible Cause	Remedy
<ul style="list-style-type: none"> Low flow, Low Pressure 	Incorrect blower rotation.	Check and correct blower rotation if required.
	Dirty or contaminated filters.	These items MUST be changed regularly (minimum of 6 months) dependant on amount of use.
	Damaged hose lining.	Replace damaged hose.
	Air leaks in system.	Check / replace damaged hose and clips.
	Drive belt slipping/Worn Pulley	Replace transmission parts.
	Incorrect speed from control system.	Check inverter / soft start / star delta settings.
	Unapproved drive belts being fitted	Replace existing drive belt with ACI approved belt.
	Closed or damaged valve	Check valve and replace if damaged.
<ul style="list-style-type: none"> High flow, Low Pressure 	Blower speed too high for application.	Reduce blower speed by using inverter or reducing pulley size.
	Operating frequency too high – maximum head speed must not exceed 20,000 rpm.	Check design frequency and reduce by inverter or change pulley size.
<ul style="list-style-type: none"> Frequent EPI0A Drive Belt Failure 	Incorrect belt tension	Check belt tension and correct if necessary.
	Motor pulley out of alignment	Check pulley alignment and correct if necessary.
	Pulley grooves worn	Replace transmission parts.
	Hostile environment (belts contaminated)	Replace belt, clean pulleys and protect blower from hostile environment.
	Incorrect belt fitted.	Replace existing belt with ACI approved belt.
	Incorrect belt installation method (Rolling belts onto pulleys)	Read EPI0A manual for correct installation and do not roll belts.
	Liquid entering blower inlet	Isolate blower from any source of liquid.
	Incorrect starting ramp time	If an inverter is used, a 4 second ramp up time is recommended. If a star/delta timer is used ensure there is no delay between switching from star to delta.
	Too many stop/starts	Avoid high number of stop starts (a maximum of 6 per hour) unless using a frequency inverter. Suggested minimum inverter setting = 30Hz.

<ul style="list-style-type: none"> Electrical Overloading 	Blower exceeding rated CFM	Reduce 'open area' of air delivery devices – i.e. slot width of Air Knives.
	Blower not piped to system correctly.	Only run blower when connected to the operating system. Never run in isolation.
	Blower RPM too high	Reduce blower speed via inverter or change pulley size.
	Motor has winding or bearing damage	Contact ACI immediately.
	Electrical supply problems	Ensure that supply voltages match with the motor rating plate details.
	Leak in air delivery ducting	Replace any damaged ducting
<ul style="list-style-type: none"> Irregular/Excessive Noise 	Blockage in air delivery ducting	Check all ducting and air delivery devices for blockages/damage. Replace as necessary.
	Leak in air delivery ducting	Check and replace damaged hose and clips.
	Inlet silencer damaged (internally)	Replace main EPI0A filter housing.
	Loose drive belt	Check belt tension and correct if necessary.
	Bolts loose on blower/motor assembly	Regular maintenance and checking/tightening all bolts.
	Motor mounts loose	Regular maintenance and checking/tightening all mounts.
	Blower bearings worn	Contact ACI Immediately.
	Motor bearings worn	Contact ACI immediately.
	Blower RPM too high	Reduce blower speed via inverter or change pulley size.
<ul style="list-style-type: none"> Reduced Drying Efficiency / Airflow 	Blocked inlet filter on the blower	Inspect the inlet filter on the blower and the enclosure. Clean or replace as necessary.
	Blocked JetPlates slots/nozzles	Check and clean if necessary all slots and nozzles of the system. Do not use a metal tool to remove blockages as this can result in damage. Also, never allow liquid to pass into the plenum and therefore onto the blower.
	Poor adjustment or installation settings, for example: <ul style="list-style-type: none"> Not cutting guide rails when installing JetPlates Not allowing for 25mm / 40mm air gap between JetPlates and conveyor Removal of fitted plugs for nozzles 	Please refer to 'Installation Guide' on www.aci-support.com

8. CLEANING AND INSPECTION

- **Cleaning:**



EL Units require very little maintenance. However, always electrically isolate the blower before commencing any maintenance.

Most components of the EL Drying unit can all regularly jet washed/cleaned. However, areas that must not be cleaned directly are:

- JetPlate face plates (unless disconnected and allowed to dry thoroughly before reconnection)
- Air Knife nozzles (unless disconnected and allowed to dry thoroughly before reconnection)
- Base unit / Blower - care must be taken to avoid soaking the blower and filter at all times. Best advice is not to direct a jet-wash towards toward the top enclosure.
- Additionally, the EPI0A's electric motor will need to be regularly cleaned - it is recommended this occurs every three months. This can be simply carried out by using a hard bristle brush. See Figure 8.

Cleaning Electric Motors



b. **Basic Inspection:**

The EL system should be given a basic weekly visual inspection to make sure the system is in working order and that there are no major leaks from hoses; no unusual noises/vibrations. No tools are required for this operation. Please refer to Section 4: Malfunction-Cause-Remedy for any problems.

9. WARRANTY

Air Control Industries Limited (ACI) warrants all products manufactured by ACI to be free of defects in material and workmanship for eighteen (18) months from the date of shipment.

The warranty does not apply to drive belts, filter elements or connecting hose, unless authorised by an officer of ACI. Also, not covered under the warranty is normal wear and tear, neglect or misuse of the equipment, operation in an application not approved by ACI, and alterations not performed by ACI.

All items supplied by ACI that are manufactured by others shall be warranted under the respective manufacturer's policy. Motors and other items, for which a national service network is in place, should be sent directly to that manufacturer's representative for the most prompt service. ACI will provide any support required ensuring that warranty service by others is handled in a prompt and professional manner.

The ACI warranty is limited to the repair or replacement of items shipped by ACI. At no time will ACI be liable for any of the costs to the buyer for labour, transportation or down-time resulting from defective equipment furnished by ACI, or our suppliers. Warranty will be void unless the blower head is returned complete.

It is recommended that in critical applications, a spare unit head assembly is purchased and kept as a spare part. ACI offers a 'service exchange' programme on both the complete blower head assembly and the spindle assembly. Contact ACI for prices. Upon receipt, ACI will inspect the failed unit and quote for the repair. A repair unit will be shipped from stock on receipt of an official purchase order. The customer's own blower unit will be repaired for all warranty claims.

Original Manufacturers Service Address:

Our products are manufactured in compliance with applicable international standards and regulations. If you have any queries regarding the use of our products, or if you are planning a special application, please contact:

Air Control Industries Ltd

Weycroft Avenue, Millwey Rise Industrial Est.

Axminster, EX13 5HU, UK

Tel: +44(0)845 5000 501

Fax: +44(0)0845 5000 502

Email: sales@aircontrolindustries.com

Web: www.aircontrolindustries.com

ENDS