



Air Control Industries

5MS11 Multi- Stage Blower c/w inverter

Installation, Operation & Maintenance Instruction Manual

Air Control Industries
Ref: 5MS11 Blower 2014/Iss1

TABLE OF CONTENTS:

- 1. GENERAL KEY MAINTENANCE POINTS FOR ACI BLOWERS**
- 2. GENERAL INSTRUCTIONS**
- 3. GENERAL SAFETY INSTRUCTIONS**
- 4. INSTALLATION**
- 5. COMMISSIONING**
- 6. TECHNICAL DATA AND MATERIALS**
- 7. TROUBLE SHOOTING**
- 8. WARRANTY & SERVICE EXCHANGE**
- 9. MANUFACTURER SERVICE ADDRESS:**

GENERAL KEY MAINTENANCE POINTS FOR ACI BLOWERS:

HEALTH AND SAFETY

- Never operate the blower without a finger guard fitted or without the inlet filter / ducting fitted to the blower inlet.
- The blower incorporates high speed moving parts that can cause injury.

ELECTRICAL

- Ensure that any ducting and equipment fitted to the inlet and/or discharge has a suitable resistance to ensure the motor does not draw too much current.
- Check the direction of rotation.

PLEASE NOTE: If the rotation is incorrect, air will continue to flow out of the discharge, but at approximately 60% of normal performance.

CONTROL

- The units are designed to run continuously. Avoid frequent stop starts – ACI recommend no more than 6 per hour.
- If the blower control is linked to other equipment then ensure that this does not go above the recommended number of starts and stops, if so then use a timer delay in the control to avoid frequent switching.

SITING

- Mounting – ensure the blower is isolated from vibration.
- Ensure adequate ventilation of motor. If the blower is fitted into an acoustic enclosure, adequate ventilation must be provided to ensure the internal enclosure temperature does not exceed 50 degrees Celsius.

CRITICAL MAINTENANCE

- Keep filter clean – ACI recommend cleaning every month depending on the working environment. The maximum filter element life is 6 months.
- Only filters, guards and belts can be supplied by ACI or its distributors should be fitted to the Blower.
- Keep the motor clean (Once per month) and free from dust build up.
- Check regularly for excessive noise and vibration

1. GENERAL INSTRUCTIONS

- Unpack the containers and check off all of the components against the provided delivery notes.
- Check for damage on arrival. Please check for any transit damage and report it to ACI immediately.
- Follow installation procedures, outlined in this manual.

Figure 1: Outline drawing of MS11 c/w Inverter

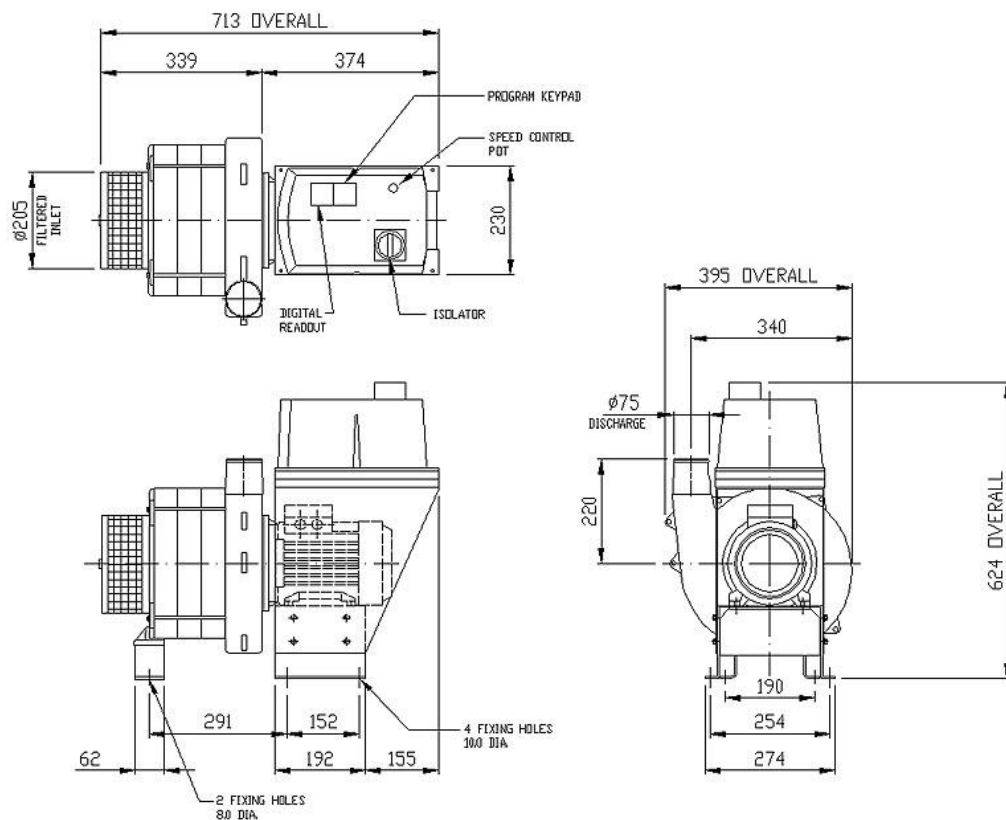

3. GENERAL SAFETY INSTRUCTIONS



DANGER!

This machinery is for use in heavy industrial current installations. During operation this unit has high speed rotating parts. For this reason, unauthorised removal of the necessary covers, improper use, incorrect operations or insufficient maintenance could lead to severe personal injury or damage of the unit.

Those responsible for the safety of the installation must ensure that:

- Only qualified personnel are allowed to work on the unit.
- These persons always have access to the operating instructions and other product documentation supplied.
- Non-qualified personnel are not permitted to work on the unit.
- Before any maintenance is carried out on the blower/inverter ensure that the power supply is locked off

Qualified personnel are persons who, on account of their training, experience and knowledge of relevant standards, specifications, accident prevention regulations and operating conditions, have been authorised by those responsible for the safety of the plant to carry out the necessary work and who can recognise and avoid possible dangers. IEE and other relevant regulations should also be observed.

It is assumed that the basic planning work for the installation and all work concerning transport, assembly, commissioning, maintenance and repair is carried out by qualified personnel.

Particular note should be taken of the following:

- Technical data and information on permissible use (assembly and connection summaries, operating conditions etc) contained in the operating/instructions and motor rating plates.
- General erection and safety regulations.
- The proper use of tools, lifting equipment and safety regulations.
- The use of personal protective equipment.

These instructions do not claim to cover all possible equipment variations, nor provide for every possible example of installation, operation or maintenance.

The specified maintenance and inspection measures must be carried out regularly by trained service personnel. Deviations from 'normal' performance (i.e. higher temperatures or vibrations) indicate that there may be a malfunction of the unit. In order to avoid faults the responsible maintenance personnel should be notified immediately.



Danger by electric shock.

If the connecting cable to the blower is damaged, there is a risk of death due to an electric shock. Such defects must be eliminated immediately.

4. INSTALLATION.

a. Important

Upon delivery of the MS11 blower/inverter to its place of installation, all safety precautions must be followed. Ensure all Fork lift trucks, elevators or cranes have enough carrying capacity and stability. Transport and installation should only be carried out by qualified personnel.

b. Transport and Mounting

The MS11 blower/inverter is an air delivery unit only, any drying system will not have been pre-fitted and will therefore need to be fitted by the end-user. For safety reasons you should never operate the MS11 without the appropriate drying system attached.

c. Site Installation

- If no other special equipment is supplied, the following requirements should apply to the installation site.
- The MS11 blower/inverter is designed for use inside closed production areas at an ambient temperature of -10 degrees to max. +40 degrees C, at an installation height of up to 1000m above sea level, protected against any weather conditions. The unit is not designed for use outside.

d. Electrical Connections

- The ACI supplied inverter is IP55 and is supplied with a lockable isolator. Connect power to the inverter in accordance with the rating plate only. A wiring diagram is provided for this purpose in the Inverter manual.
- All wiring should be installed to national wiring standards.

e. Control

- The MS11 blower/inverter is designed to run continuously. Avoid frequent stop/starts – ACI recommend no more than 15 stop/starts per hour.
- The MS11 blower/inverter requires an airflow passing through it to ensure safe operating temperatures are not exceeded. The use of control valves should be limited to ensure that a minimum of 150 CFM passes through the blower at all times.
- Avoid using fast acting valves in the ducting as these can cause sudden back pressure changes.

5. COMMISSIONING

- a. ACI recommend employing experienced staff for the installation, assembly and start-up of the unit.
- b. ACI cannot be held responsible for damage or defects caused by poor installation, assembly or start-up of the unit.
- c. Installation and commissioning procedures should be carried out in compliance with local accident prevention regulations.
- d. The MS11 blower/inverter unit provides blown air only.
- e. Do not use whilst the MS11 blower/inverter is not connected, to a suitable drying system or duct.

6. TECHNICAL DATA AND MATERIALS:

Type: MS11 model

Machine Number: Refer to Serial Number on Motor Label

Year of Manufacture: Refer to Date on Motor Label

Standard voltage: Refer to Rating Plate on Inverter

Motor type: Induction type / TEFC / IP55

Motor power: Up to 3kW, see inverter rating plate for full details

Materials: Blower materials:

- Motor – Aluminium
- Blower fancase and mounting foot – Aluminium Alloy LM6
- Pedestal & Inverter bracket – Aluminium sheet (Painted)
- Front foot support – Mild steel sheet (Painted)

7. TROUBLE SHOOTING:

(This section is not intended as an exhaustive guide to fault diagnosis, but outlines the most common faults that may be encountered.)

Condition	Possible Cause	Action
Fan stopped	Blower/Inverter power supply fuse blown	Replace with correct size fuses and investigate the reason for fuses blowing.
	Motor tripped on overload	Reset the overload and check overload setting and investigate the reason for the trip.
	Blockage between blades and casing	Find and remove blockage, inspect for damage and replace damaged parts.
Fan pressure high	Blockage downstream of fan	Remove blockage, dismantle if necessary.
	Supply frequency increased.	Do not exceed the maximum/minimum set limits of 25/75Hz.
Fan pressure low	Fan rotating backwards	Briefly apply power to the blower and check the rotation of the motor by looking at the motor cooling fan. The direction should be as per the arrow.
	Fan not running	Ensure that the power is switched on and selected to automatic, and protection has not been operated.
	Blocked inlet filter/guard and silencer	Check intake for cleanliness, clean or change filter.
Fan Vibrating	Fan blades damaged	Repair damage and rebalance or fit new impeller.
	Ductwork leakage.	Repair ductwork.
	Fan blade damaged.	Repair damage and rebalance or fit new impeller.
	Debris drawn into fan and attached to a blade.	Remove debris, repair blade and rebalance, or fit a new impeller.
	Debris in fan.	Remove and inspect for damage, repair as necessary.
Noisy fan	Motor bearing wear.	Check and fit new bearings ensuring lubrication.
	Fan impeller loose.	Tighten or re-weld, test for vibration.
	Discharge area too large.	Check for ducting leaks. Check total discharge area is as per system design.
Fan drawing high current	Motor bearing wear.	Check and fit new bearings ensuring lubrication.
	Increase in motor speed.	Check that the supply frequency is correct.

8. WARRANTY & SERVICE EXCHANGE:

Air Control Industries Limited (ACI) warrants all products manufactured by ACI to be free of defects in material and workmanship for twelve (12) months from the date of shipment. The warranty does not apply to drive belts, filter elements or connecting hose, unless authorised by an officer of ACI. Also, not covered under the warranty is normal wear and tear, neglect or misuse of the equipment, operation in an application not approved by ACI, and alterations not performed by ACI.

All items supplied by ACI that are manufactured by others shall be warranted under the respective manufacturer's policy. Motors and other items, for which a national service network is in place, should be sent directly to that manufacturer's representative for the most prompt service. ACI will provide any support required ensuring that warranty service by others is handled in a prompt and professional manner.

The ACI warranty is limited to the repair or replacement of items shipped by ACI. At no time will ACI be liable for any of the costs to the buyer for labour, transportation or down-time resulting from defective equipment furnished by ACI, or our suppliers.

To comply with the Warranty the complete fan unit must be returned to ACI. Disassembly of the fan will invalidate the warranty.

9. MANUFACTURER SERVICE ADDRESS:

Our products are manufactured in compliance with applicable international standards and regulations. If you have any queries regarding the use of our products, or if you are planning a special application, please contact the nearest ACI office:

Air Control Industries Ltd

Weycroft Avenue, Millwey Rise Industrial Est.

Axminster, EX13 5HU, UK

Tel: +44(0)845 5000 501

Fax: +44(0)0845 5000 502

Email: sales@aircontrolindustries.com

Web: www.aircontrolindustries.com