



Air Control Industries

DRI-Line Series JetPlates

JetPlate Overview:

Derived from ACI Air Knife Technology, JetPlates have been purposely designed to improve the efficiency of ACI's Drying Systems whilst also simplify installation and on-site maintenance.

The benefits and features of ACI's JetPlates include:

- When compared to standard Air Knives, JetPlates deliver twice the volume of high pressure air over product
- The design of the JetPlates allows for the blower-driven air to be delivered within 3mm of the product. This is because the faceplate acts as the conveyor guide rail.
- The slot design incorporated into the JetPlates enables all moisture to be directed downwards and away from the conveyor line, thereby preventing any recontamination.
- The installation of Jetplates simplifies installation, maintenance and operation processes.
- The Jetplate design requires no pitch adjustment to achieve optimum drying performance.

Configurations:

JetPlates are available with a number of slot designs and plenum sizes. These are completely dependant on factors such as the bottle shape and size, speed of the line and the nature of the label type being applied.

JetPlates can also be used in conjunction with Air Knives and/or cap and neck dryers. This configuration will again be determined by factors dictated by the application.

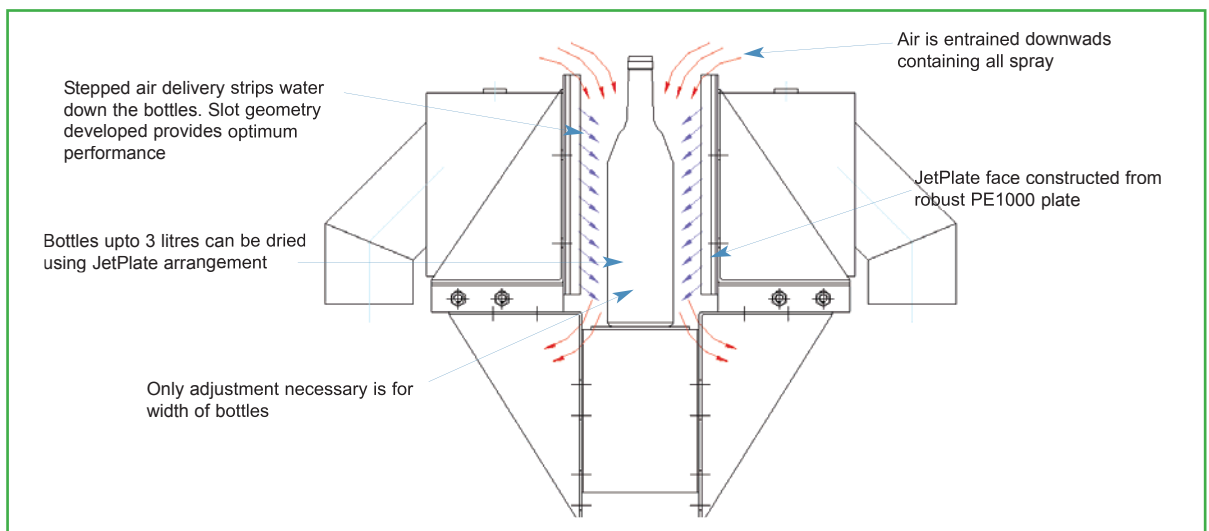
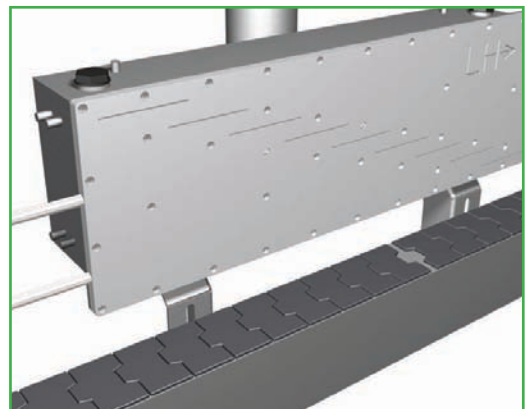
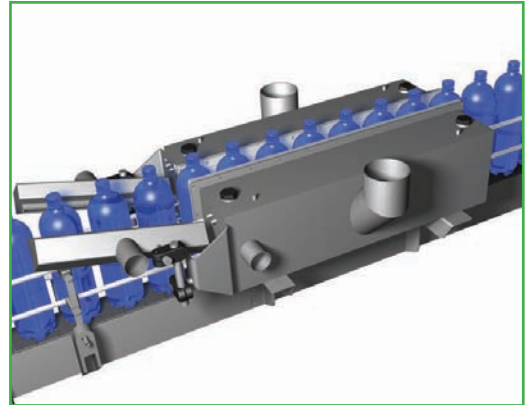

Drying Systems for the Filling Industry
www.bottlecandrying.com



Air Control Industries

DRI-Line Series JetPlates

Jetplate and Air Knife outline drawing:

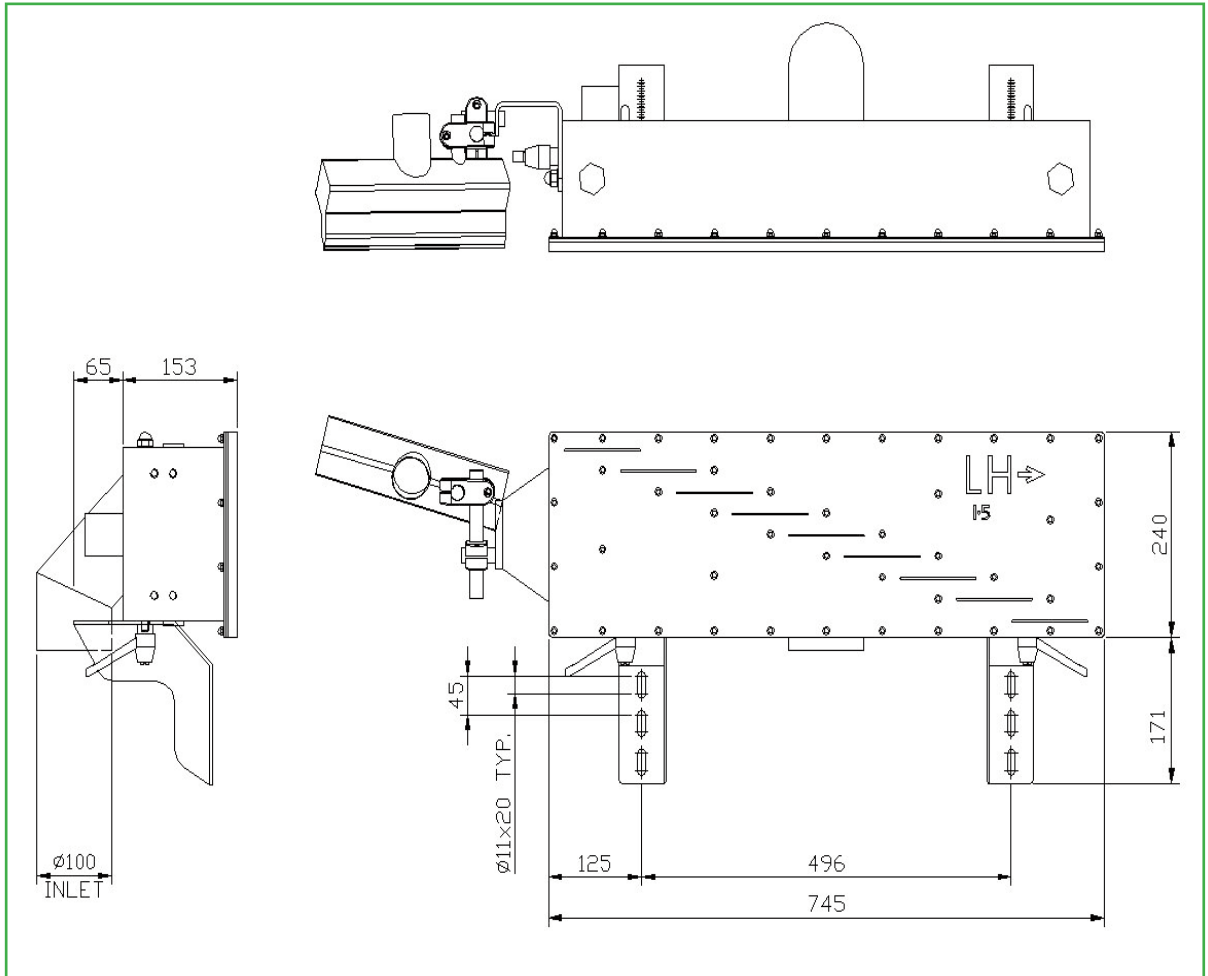

JetPlate mountings:

- JetPlates will be supplied with a set of mounting brackets that will need to be directly attached to the existing conveyor (fixings are not supplied as standard).
- JetPlates will need to be mounted so that the slots of the dryer are in line with, and close to the neck of the product being dried.
- JetPlates can be moved to suit various sizes of product by simple 'slide' adjustment.



Ref: DRI-Line DS 2014/V1

Please note (1) - all drawings measurements are in millimeters (mm)
Please note (2) - above technical specifications are subject to change

Air Control Industries Ltd

Weycroft Avenue, Millwey Rise Industrial Estate,
Axminster, Devon, EX13 5HU, United Kingdom
Tel: +44 (0)1297 529 242 Fax: +44 (0)845 5000 502
Email: sales@aircontrolindustries.com

www.bottlecandrying.com