



Air Control Industries

'Cb-C' - Craft Brewery Can Drying System

Configuration	Craft Brewery Can Drying System
Product Category	All Cans (330-566ml)
Application Area	Drying can tops or bottoms, and sides

ACI's 'Cb-C' Craft Brewery Can Drying System is specifically designed to surface dry aluminum cans within craft and micro-brewery operations - whether drying for date coding or packaging. Using a small 5.5kW centrifugal, radial bladed blower, ACI's 'Cb-C' system is suitable for line speeds lower than 6,000 cans per hour and designed to be easily installed, operated and maintained. Noise levels are 87 dB(A) with the polyethylene spray cover and 90 dB(A) without. An additional acoustic enclosure is available for the blower, if required. These systems are capable of drying can sizes 330-568ml, providing a water removal efficiency figure of 96.5%, and are backed up with a 24 month warranty.

'Cb-C' illustrated:

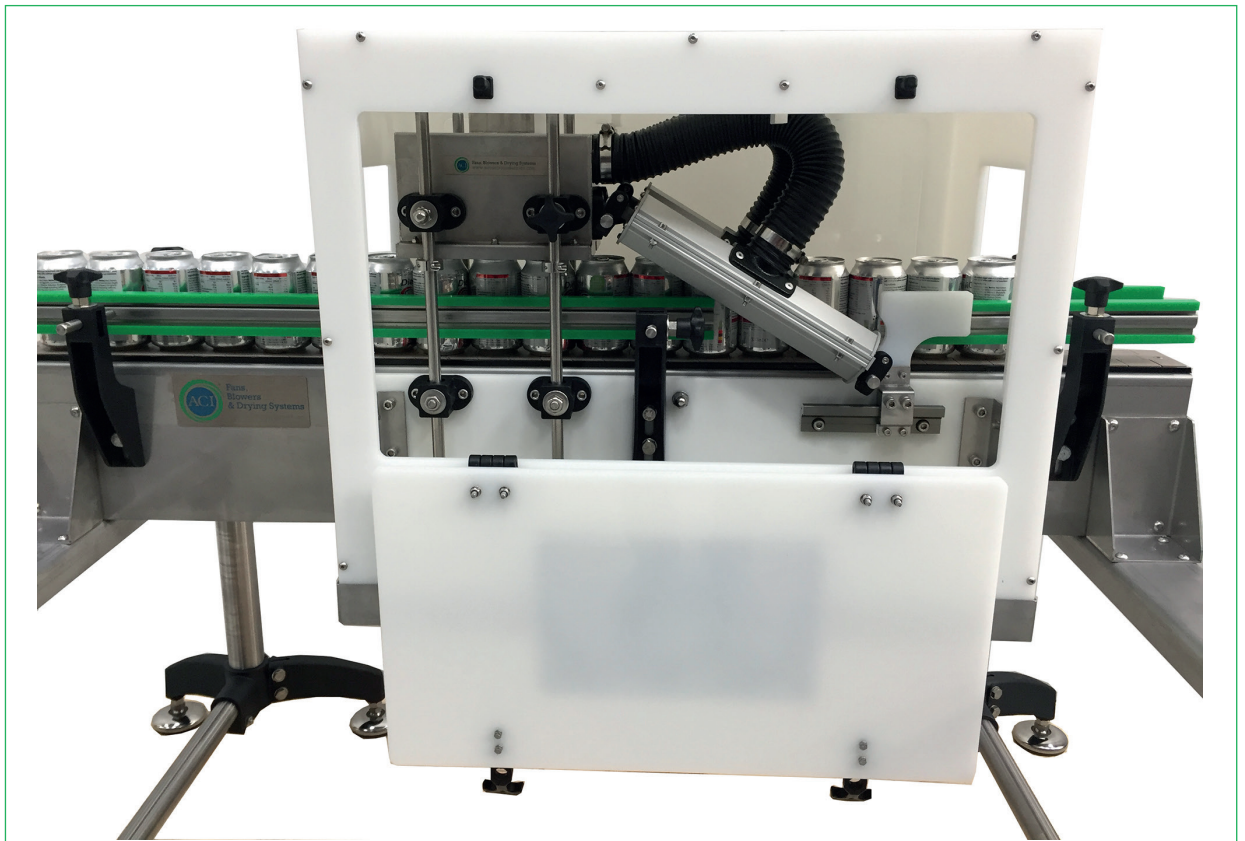

'CB-C' Items	Quantity
Stainless steel 'Y' slot drying plenum chamber	1
AK05 anodized aluminium air knives, 300mm long	2
Clamping kits	2
5.5kW Centrifugal Blower (Model APE 711)	1
Polyethelene Mounting Plates	2
Optional polyethelene cover	1
Flexible ducting	5m
Jubilee clips	2

Drying Systems for Craft & Micro-Breweries
www.bottlecandrying.com



Air Control Industries

'Cb-C' - Craft Brewery Can Drying System

www.bottlecandrying.com

'Cb-C' outline drawing
(Conveyor not included)

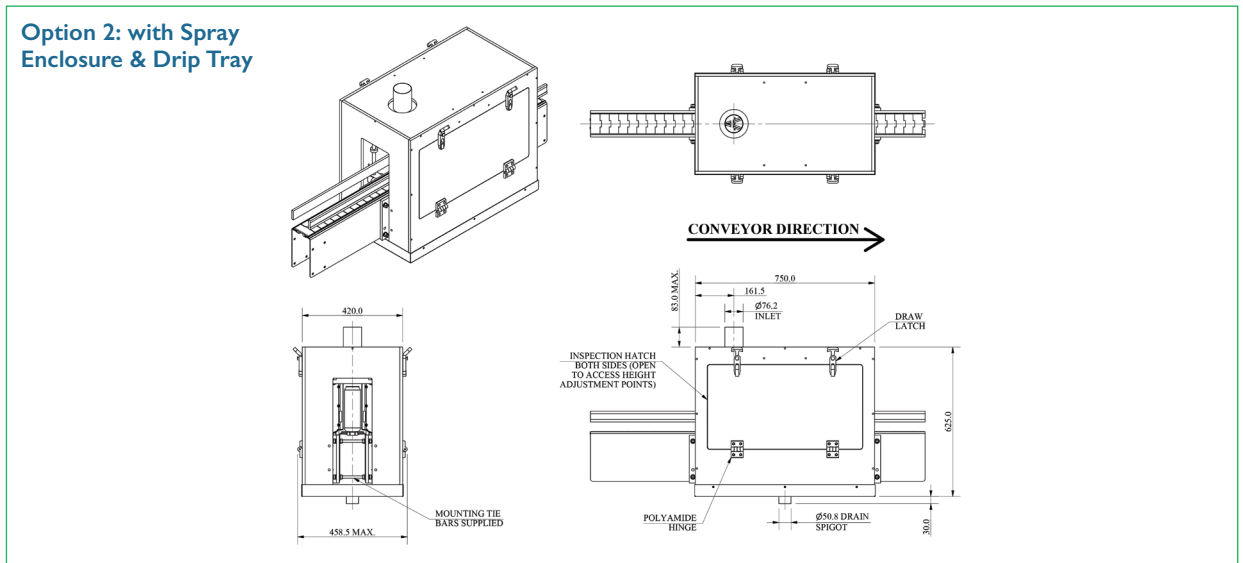
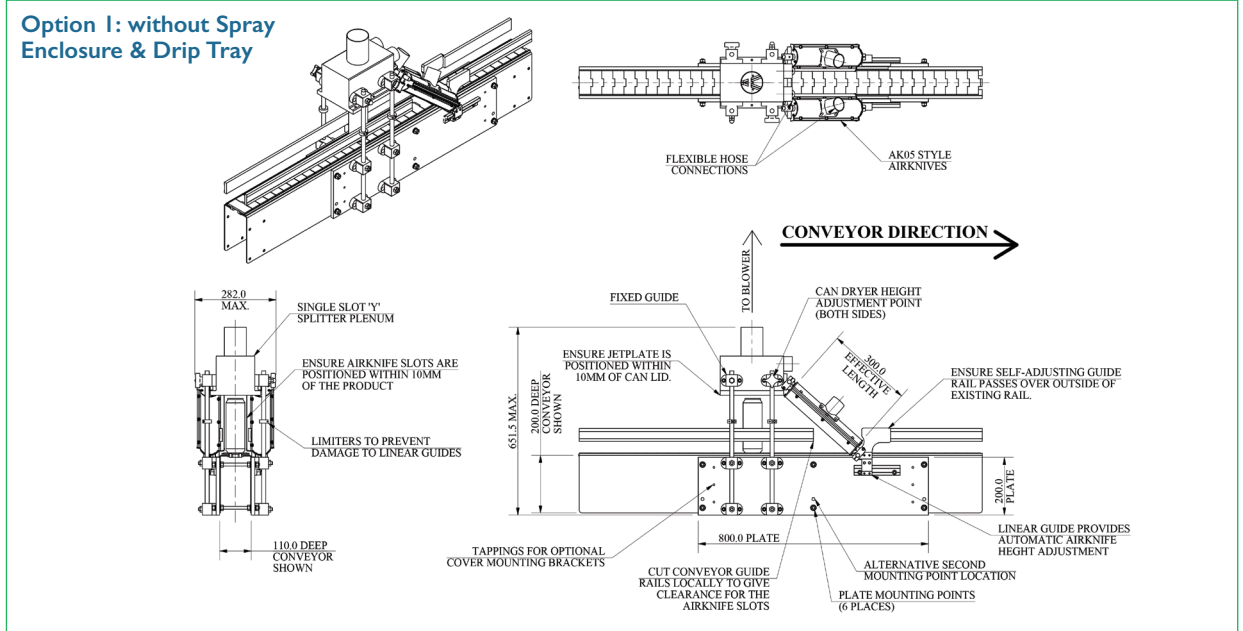

Please note (1) - all drawings measurements are in millimeters (mm)
Please note (2) - above technical specifications are subject to change

Comparisons to Compressed Air:

- More cost effective - in operation running costs reduced by as much as 90%.
- Quieter – lower air pressures used reduces the expansion ratio and turbulence of the air produced.
- Cleaner – blower-driven air is both dry and oil free. No expensive additional filtration required.
- Safer – centrifugal blowers operate on the principle of high velocity, low pressure air which presents no danger to operators.

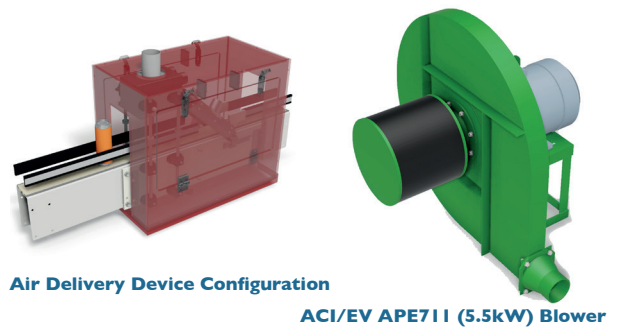

Air Control Industries Ltd
Weycroft Avenue, Millwey Rise Industrial Estate,
Axminster, Devon, EX13 5HU, United Kingdom
Tel: +44(0)1297 630960
Email: sales@aircontrolindustries.com