



AIR CONTROL INDUSTRIES

shaping air movement since 1969

Spot Dryer

The Efficient Alternative To Compressed Air Nozzles

The Spot Dryer (AZ-100) is a targeted drying solution designed for precise applications in various industrial environments.

This innovative system replaces traditional compressed air nozzles with efficient centrifugal blower technology, providing powerful performance in a compact design that integrates seamlessly into existing production lines.

Why Choose the Spot Dryer?

- **Up to 95% reduction in energy costs** compared to compressed air systems
- Minimise reliance on costly compressed air systems and reduce associated maintenance costs
- Improved production quality through consistent, targeted drying
- Reduced product waste from coding and labelling issues
- Enhanced quality control with reliable, precise moisture removal
- Lower maintenance requirements and decreased downtime
- Immediate positive impact on sustainability goals
- Quick return on investment through energy and operational savings

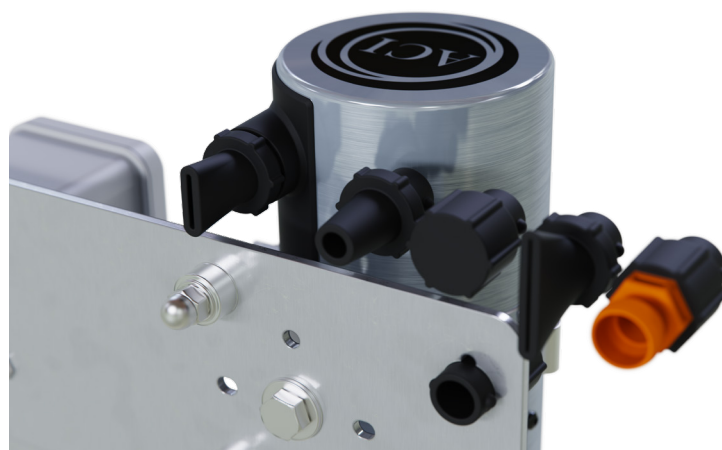

Spot Dryer

The Efficient Alternative To Compressed Air Nozzles

Simple by Design:

By choosing the Spot Dryer, you invest in a transformative solution that improves product quality, increases operational efficiency, and contributes to a more sustainable manufacturing process.

Experience the future of precision drying with a system that pays for itself through energy savings while addressing your specific production challenges.

Key Features:

- **High-Efficiency Centrifugal Blower:** Delivers powerful performance while maintaining energy efficiency.
- **Low Noise Operation:** 75 dBA noise level for a more comfortable working environment.
- **Compact Footprint:** Requires less than 300mm of line space, maximising production floor efficiency.
- **Versatile Nozzle Options:** Available with five different nozzle types as standard.
- **Flexible Power Compatibility:** Compatible with a wide range of power supplies for versatile installation options.
- **Safety Certified:** Meets UKCA and CE safety standards for reliable and compliant operation.
- **Easy Integration:** The Spot Dryer installs easily on existing production lines, minimising downtime and setup complexity
- **Durability & Reliability:** Built for long-term use in demanding industrial environments, reducing maintenance and downtime.

Performance Data:

Dimensions	Compact Design < 300 mm Line Space
Power Supply	100-305 VAC. 50/60Hz 1Ph
Weight	5 Kg
Noise Level	75 dBA
Construction	Stainless Steel & Polymer
Installation	Direct Conveyor Mount
Certifications	UKCA, CE, Suitable for food and beverage environments

Support and Service:

- Comprehensive installation guidance
- Technical support
- Energy savings calculation tools



Spot Dryer

The Efficient Alternative To Compressed Air Nozzles

Typical Applications:

- Pre-date coding surface preparation
- Spot drying of critical areas
- Air rinsing of containers
- Sensor clearing and maintenance
- Enhanced product handling
- Process debris removal and de-dusting
- Critical surface moisture elimination

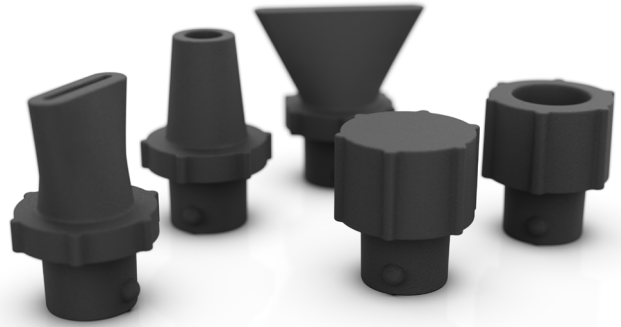

Outline Drawing: Spot Dryer - AZ-100

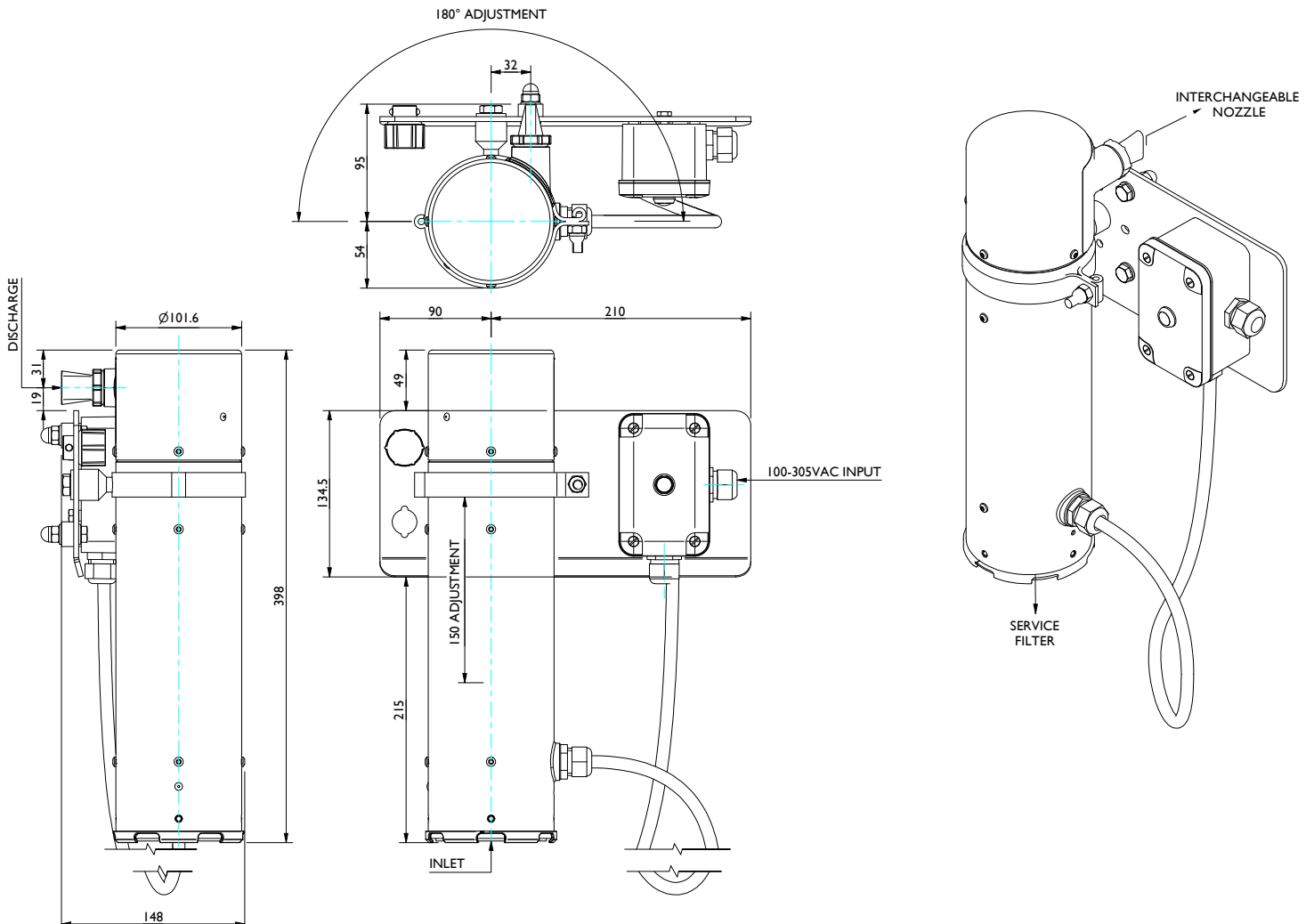



AIR CONTROL INDUSTRIES

shaping air movement since 1969



Air Control Industries Ltd

Weycroft Avenue, Millwey Rise Industrial Estate,
Axminster, Devon, EX13 5HU,
United Kingdom

Tel: +44 (0)1297 630960

Email: sales@aircontrolindustries.com

Web: aircontrolindustries.com

Air Control Industries Inc

76 Augusta Rockland Road
Windsor, Maine, ME 04363,
United States

Tel: +1 (207) 445 2518

Email: inquiries@aci-inc.com

Web: aircontrolindustries.com/us